

Strateški procesi

Strateško upravljanje

Kupac

Upravljanje dobavljačima

Upravljanje marketingom

Upravljanje prodajom

Izvršenje narudžbe kupaca

Upravljanje proizvodnjom

Upravljanje poslijeprodajnim aktivnostima

Kupac

Radni procesi

Upravljanje ljudskim resursima

Upravljanje materijalnim resursima

Upravljanje IKT-om

Upravljanje rizicima i usklađenošću

Upravljanje poslovnim sposobnostima

Podržavajući procesi



Strateško upravljanje

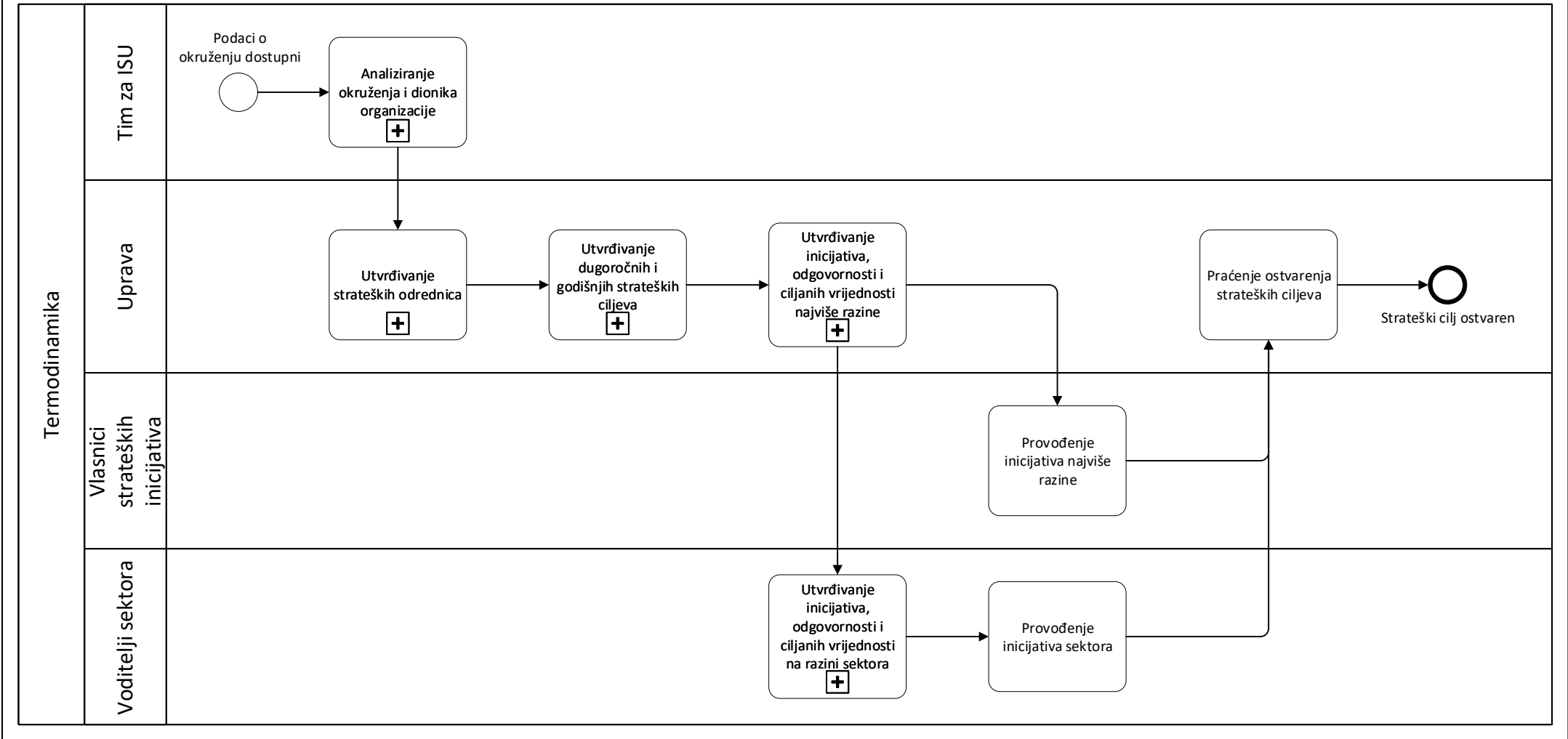



Analiziranje okruženja i dionika organizacije

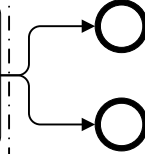
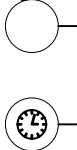
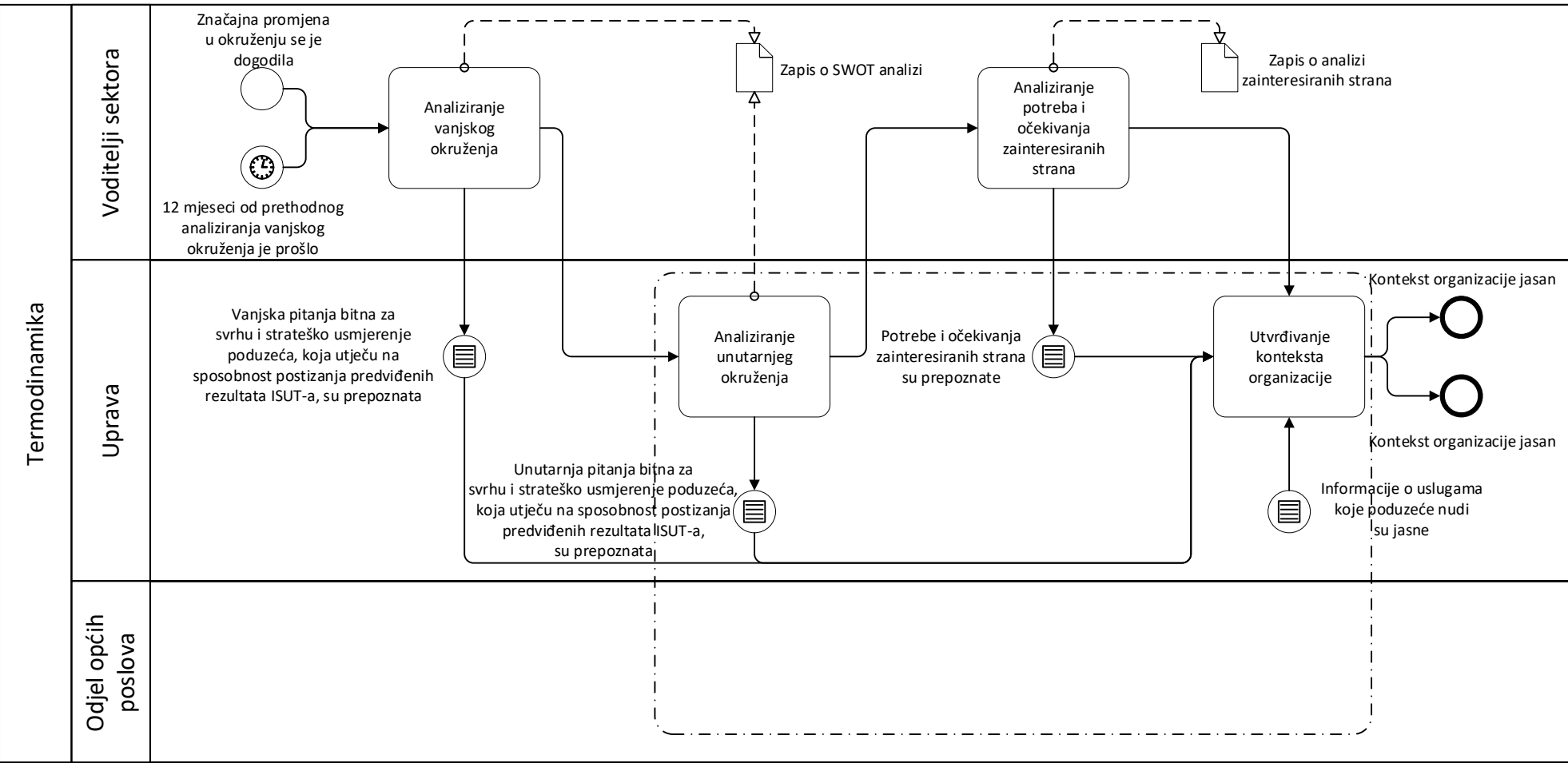

<

Utvrđivanje strateških odrednica

H

Termodinamika

Uprava

Kontekst
organizacije je
jasanProsudivanje
primjerenost
postojeće
misije

Primjerenost?

Da

Utvrđivanje nove
misije

Ne

Prosudivanje
primjerenost
postojeće
vizije

Primjerenost?

Da

Utvrđivanje nove
vizije

Ne

Prosudivanje
primjerenost
strateške
destinacije

Primjerenost?

Da

Utvrđivanje nove
strateške
destinacije

Ne

Obavještanje
dionika o
strateškim
odrednicamaAžuriranje iskaza
o misiji, viziji i
strateškoj
destinacijiDjelatnici i, po potrebi,
ostali dionici upoznati su
s misijom, vizijom i
strateškom destinacijom



Utvrđivanje dugoročnih i godišnjih strateških ciljeva

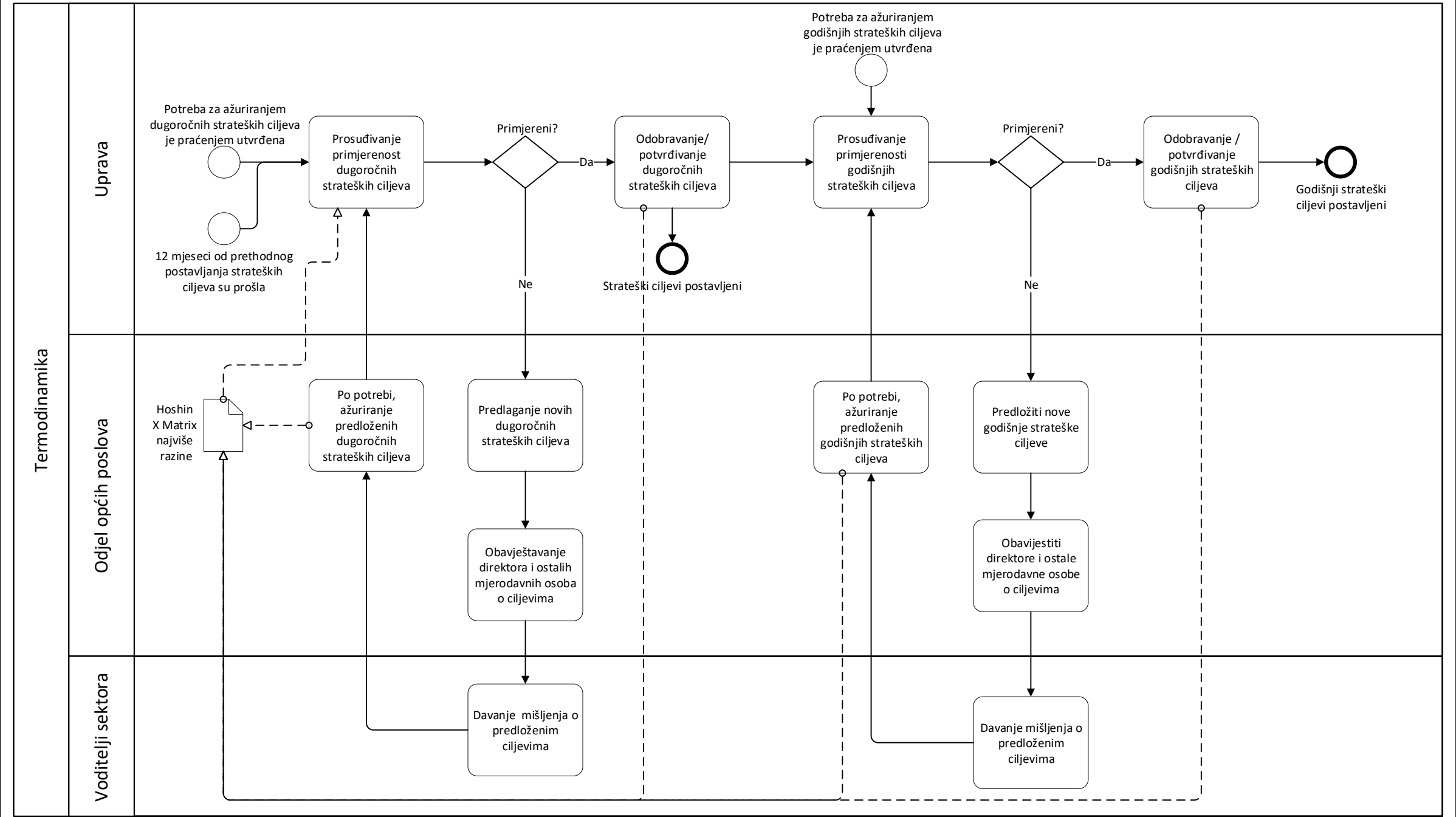

Utvrđivanje inicijativa, odgovornosti i ciljanih vrijednosti najviše razine

<

H

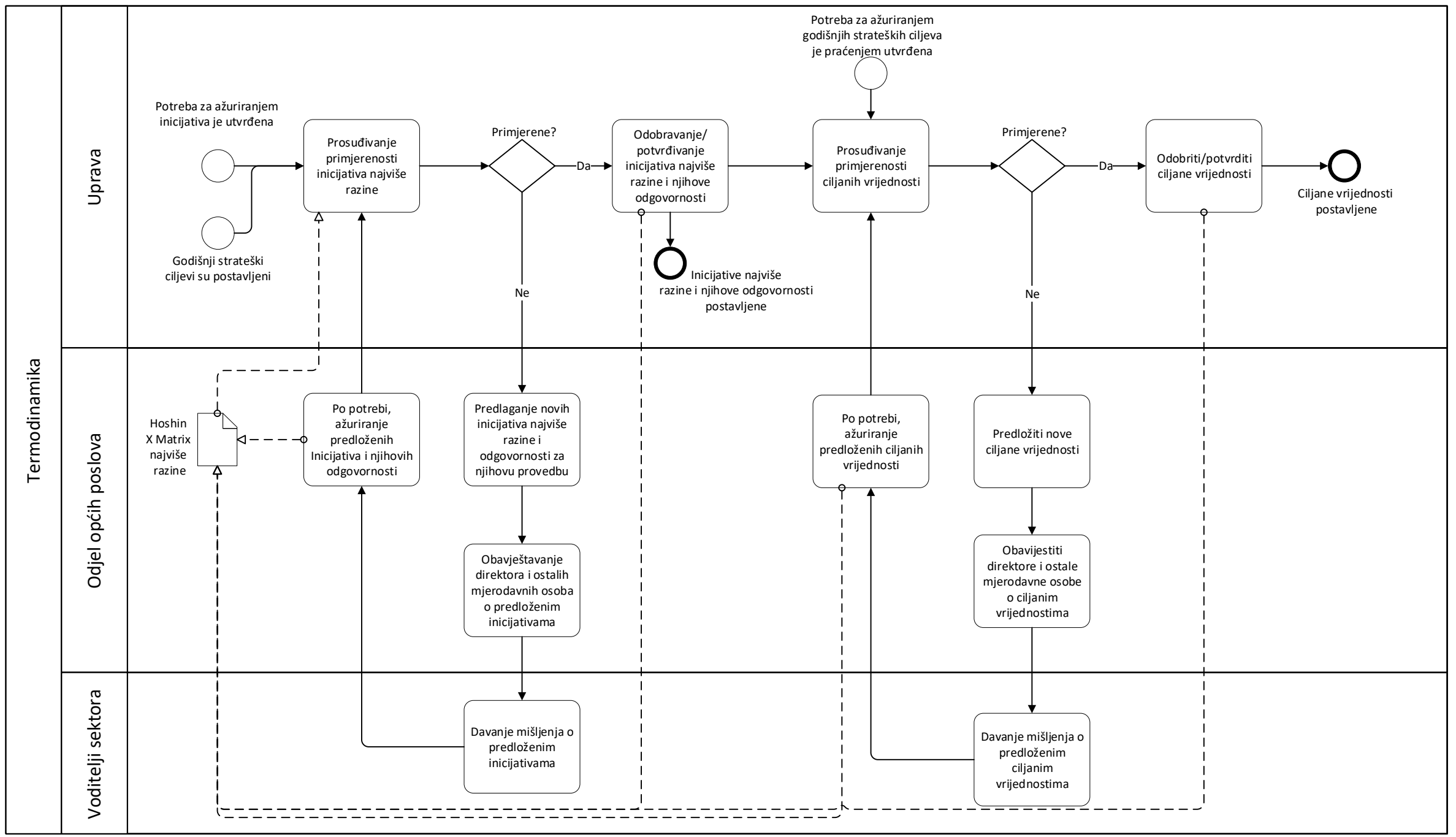

Utvrđivanje inicijativa, odgovornosti i ciljanih vrijednosti na razini sektora

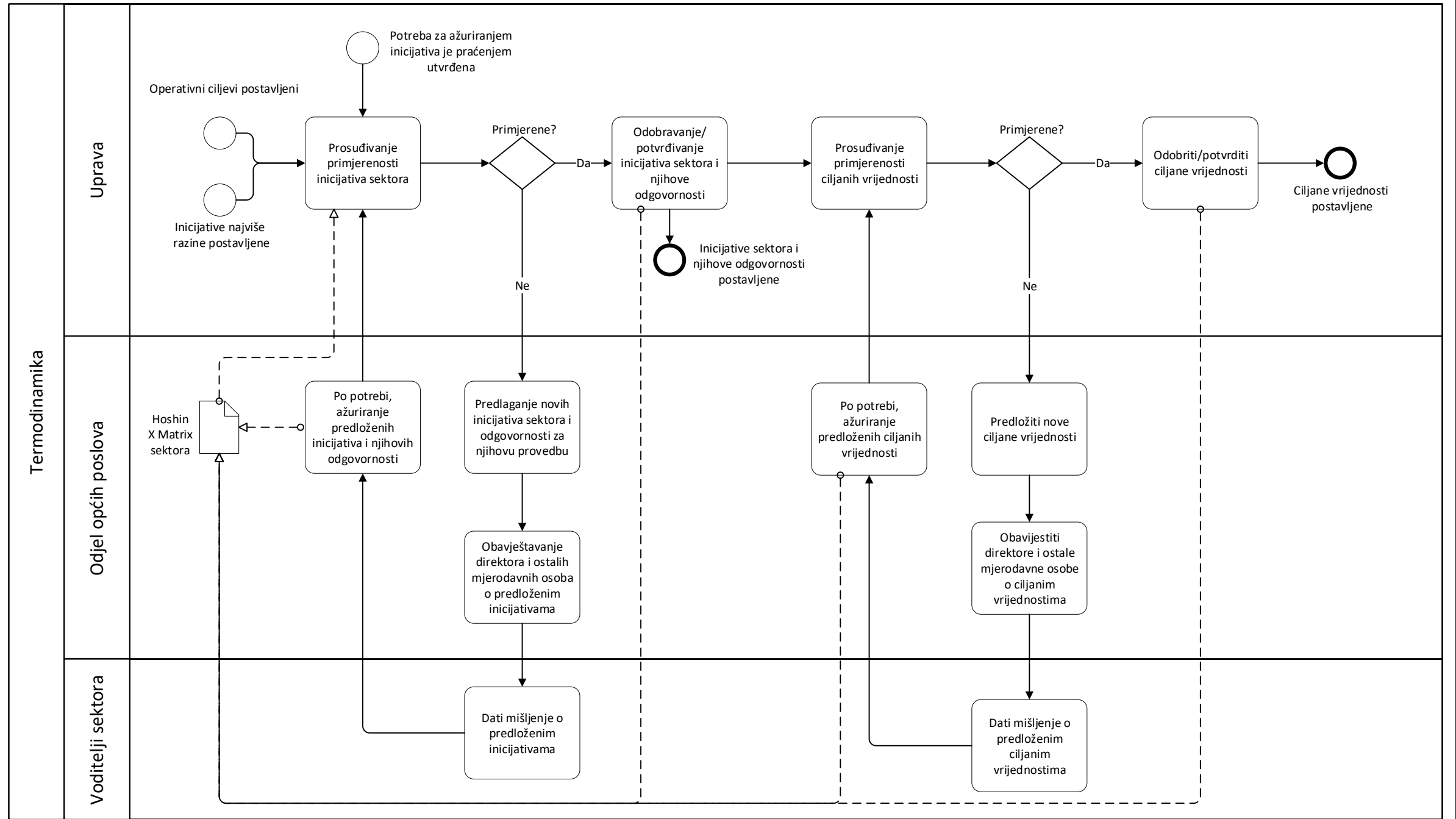



Upravljanje dobavljačima

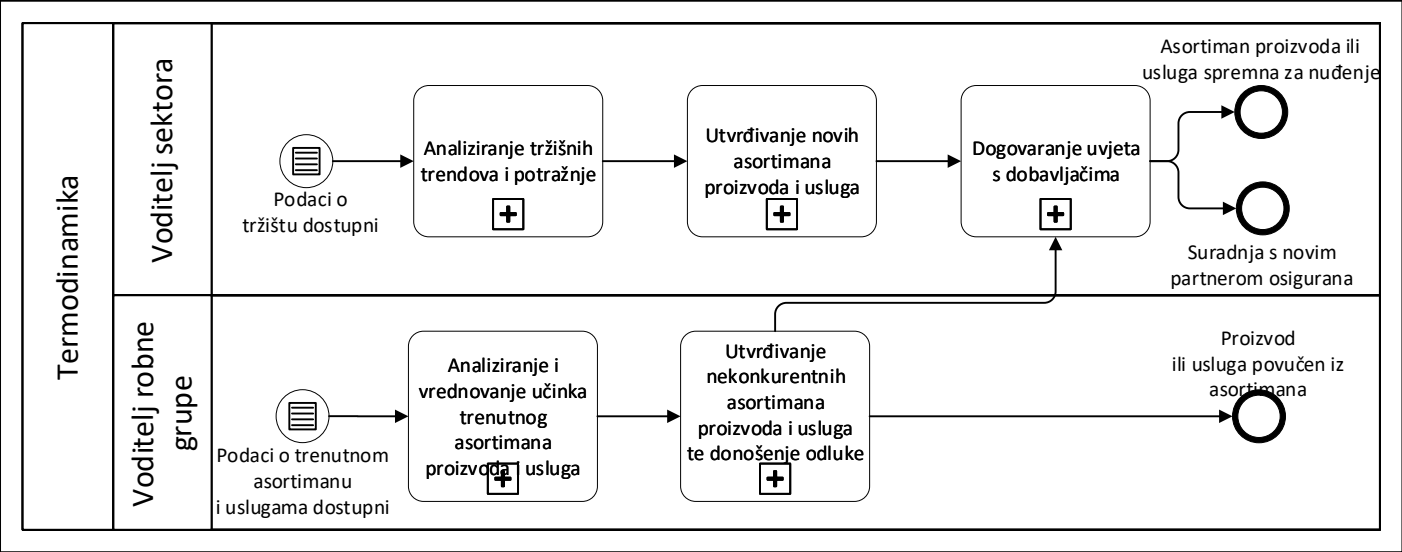

<

H

Analiziranje tržišnih trendova i potražnje

Termodinamika

Komercijalist

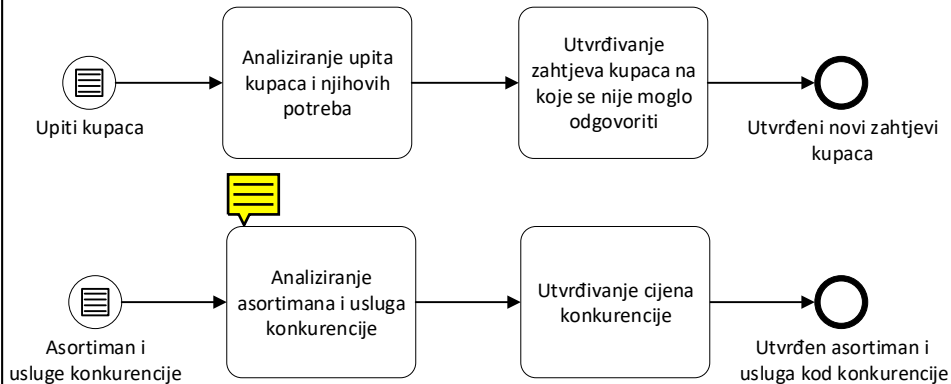



Utvrđivanje novog asortimana proizvoda i usluga

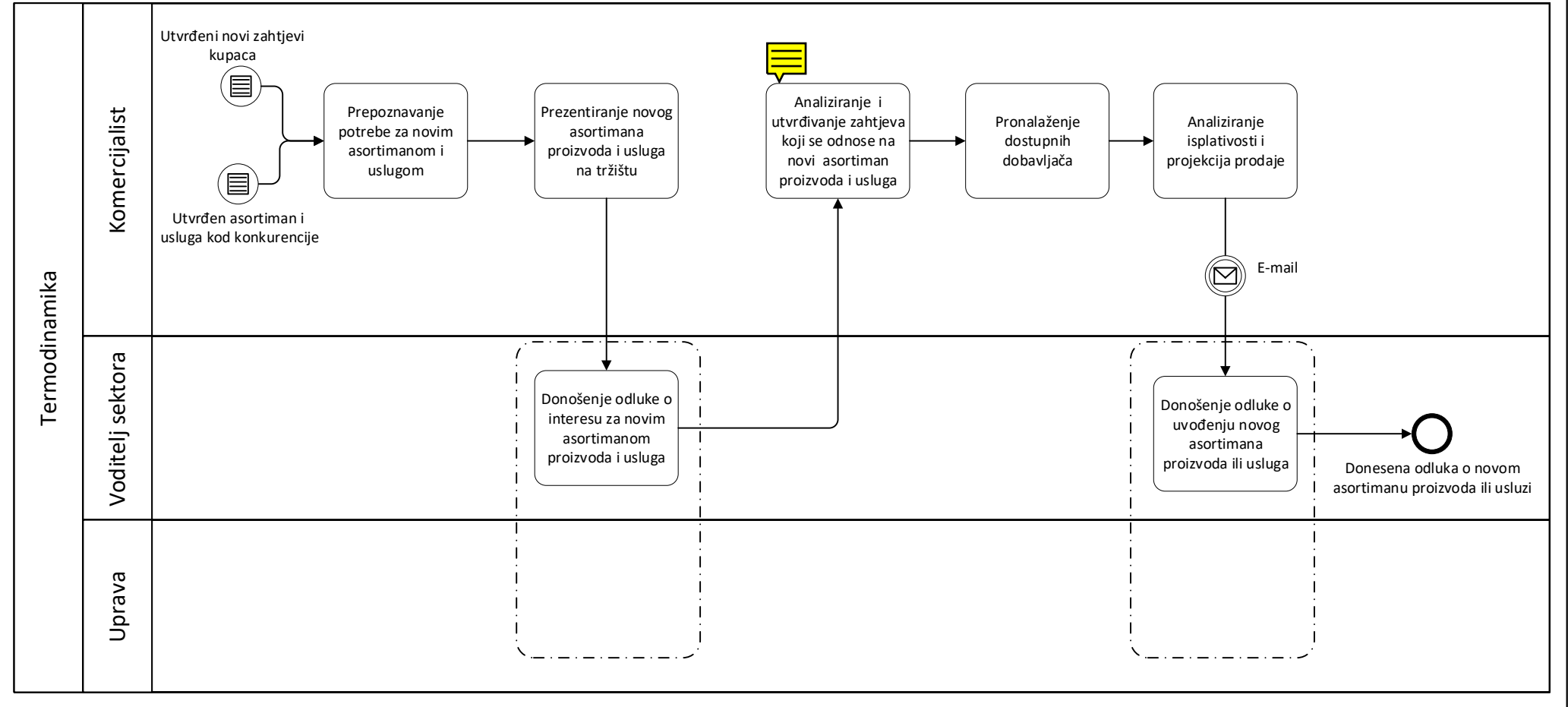



Dogovaranje uvjeta s dobavljačima

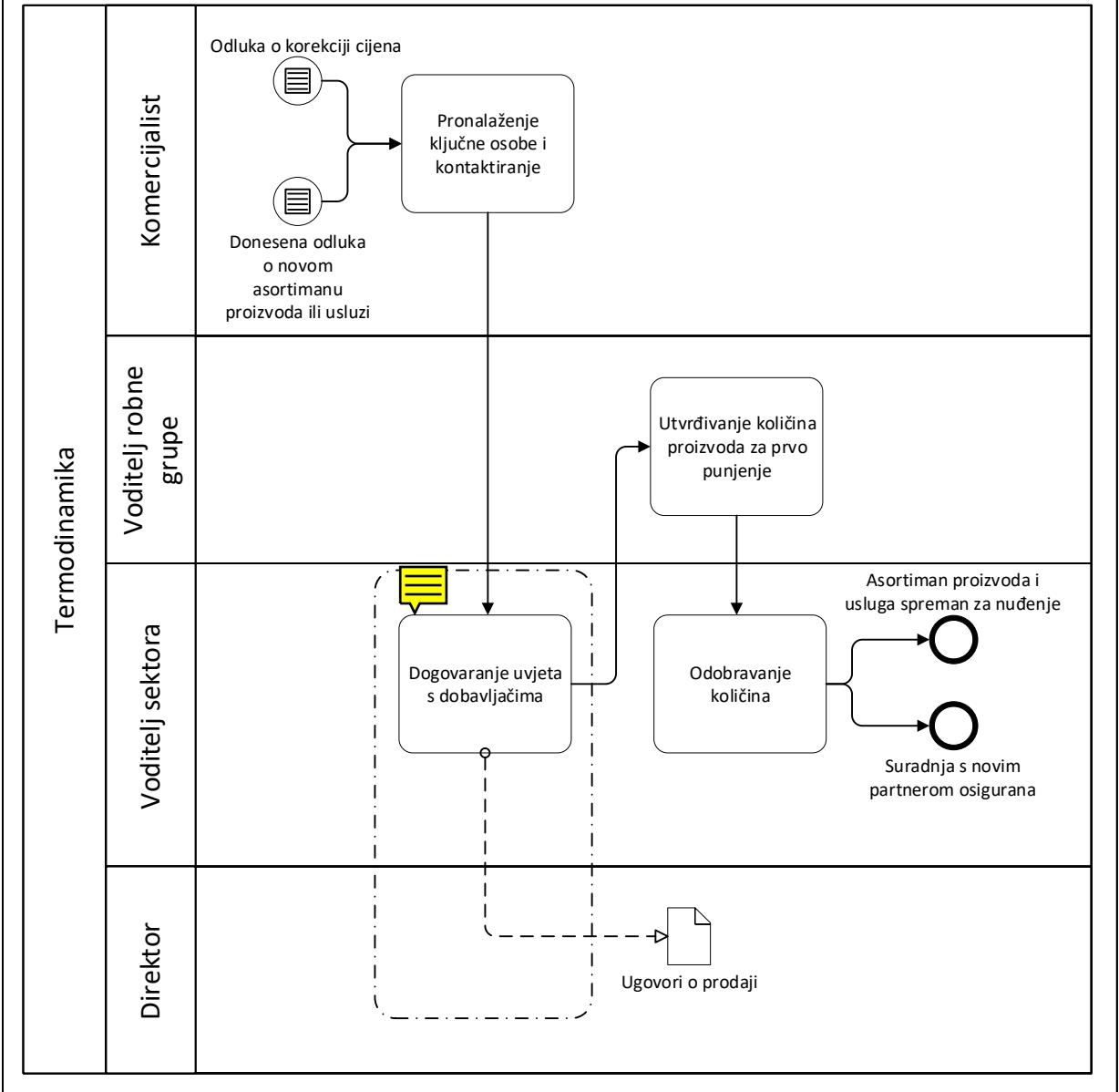

<

Analiziranje i vrednovanje učinka trenutnog asortimana proizvoda i usluga

H

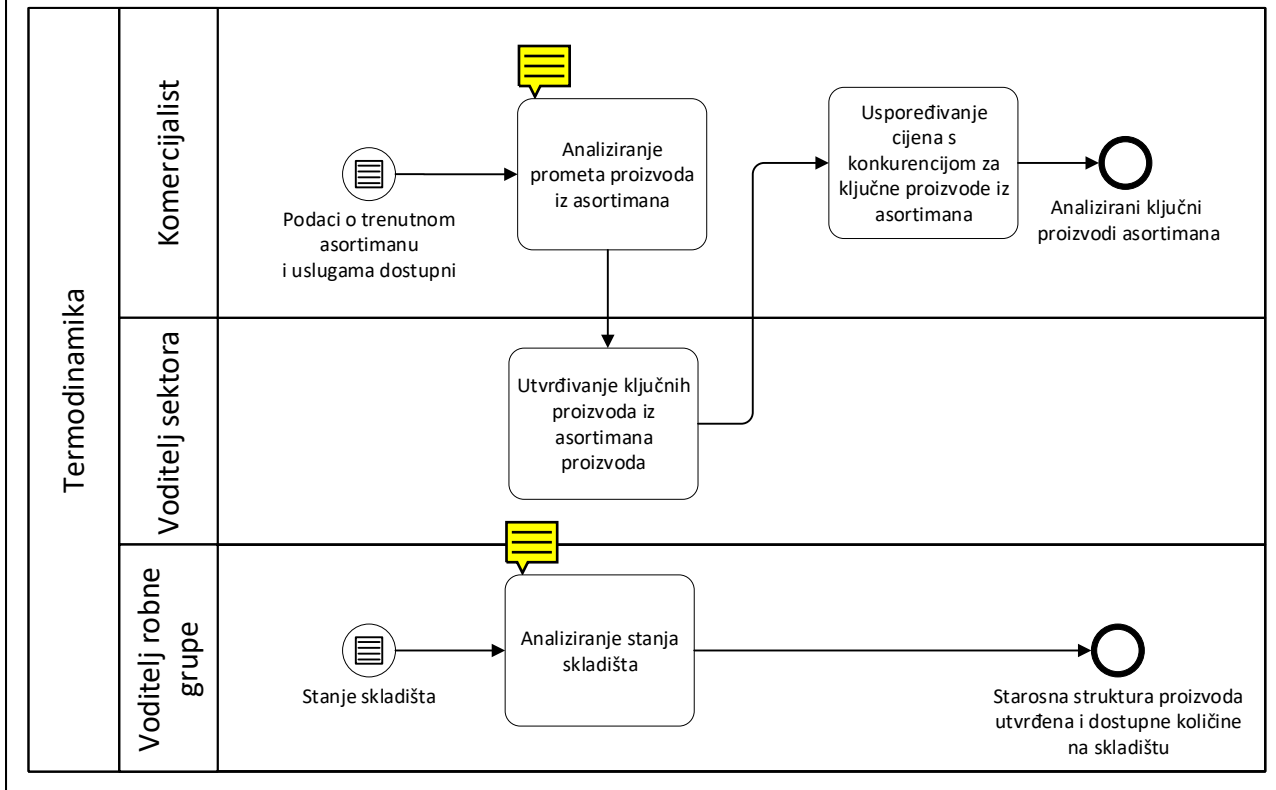

Utvrđivanje nekonkurentnih asortimana proizvoda i usluga te donošenje odluke

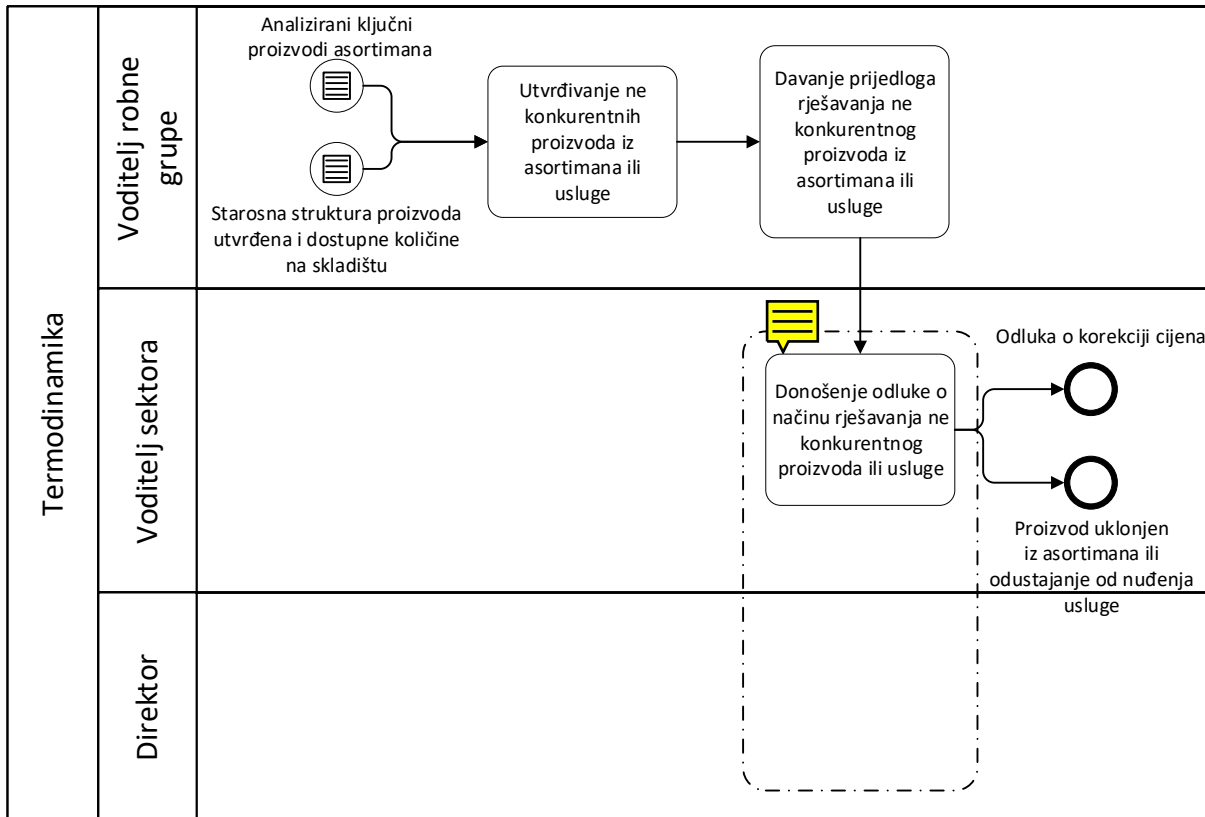



Upravljanje marketingom

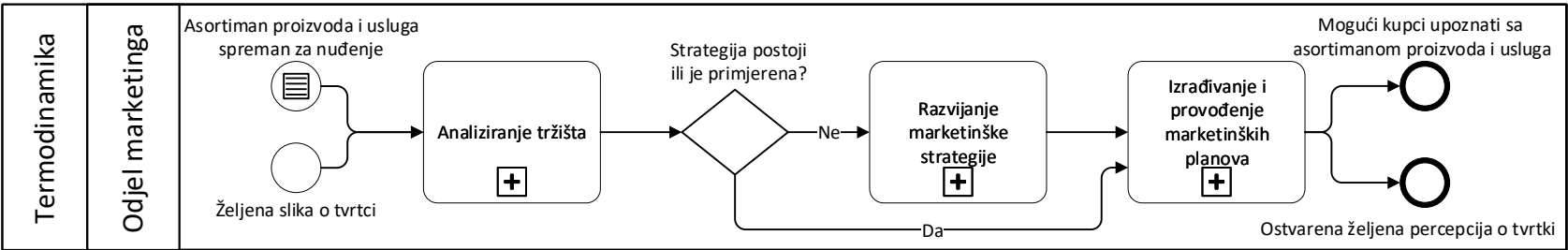



Analiziranje tržišta

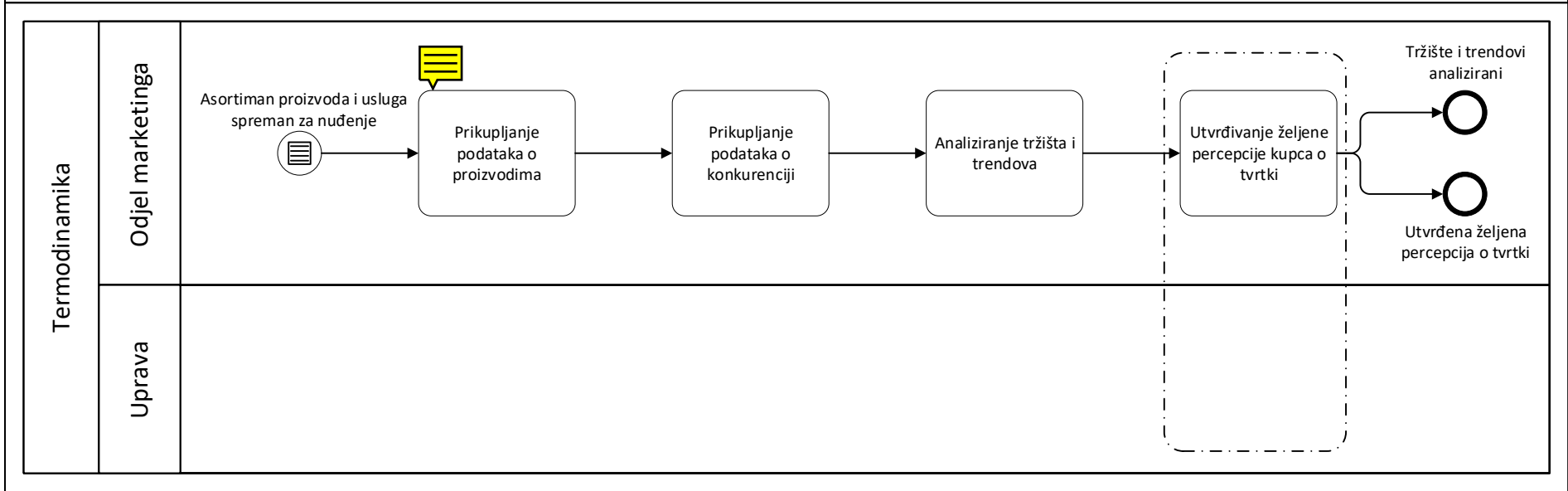



Razvijanje marketinške strategije

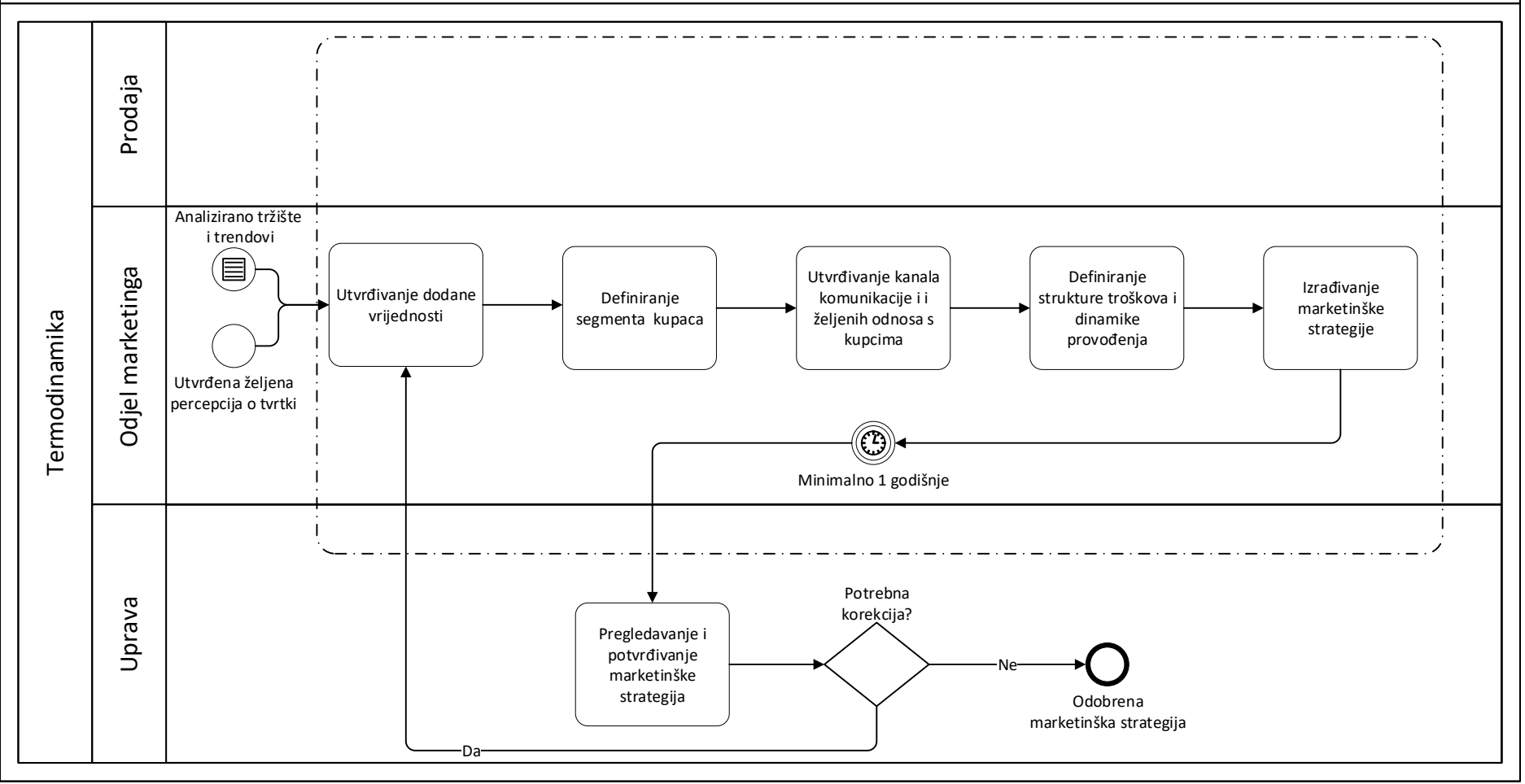

Analizirano tržište i trendovi



Utvrđena željena percepcija o tvrtki

Utvrđivanje dodane vrijednosti

Definiranje segmenta kupaca

Utvrđivanje kanala komunikacije i i željenih odnosa s kupcima

Definiranje strukture troškova i dinamike provođenja

Izrađivanje marketinške strategije



Minimalno 1 godišnje

Pregledavanje i potvrđivanje marketinške strategija

Potrebna korekcija?

Ne



Odobrena marketinška strategija

Da

Izrada i provođenje marketinškog plana

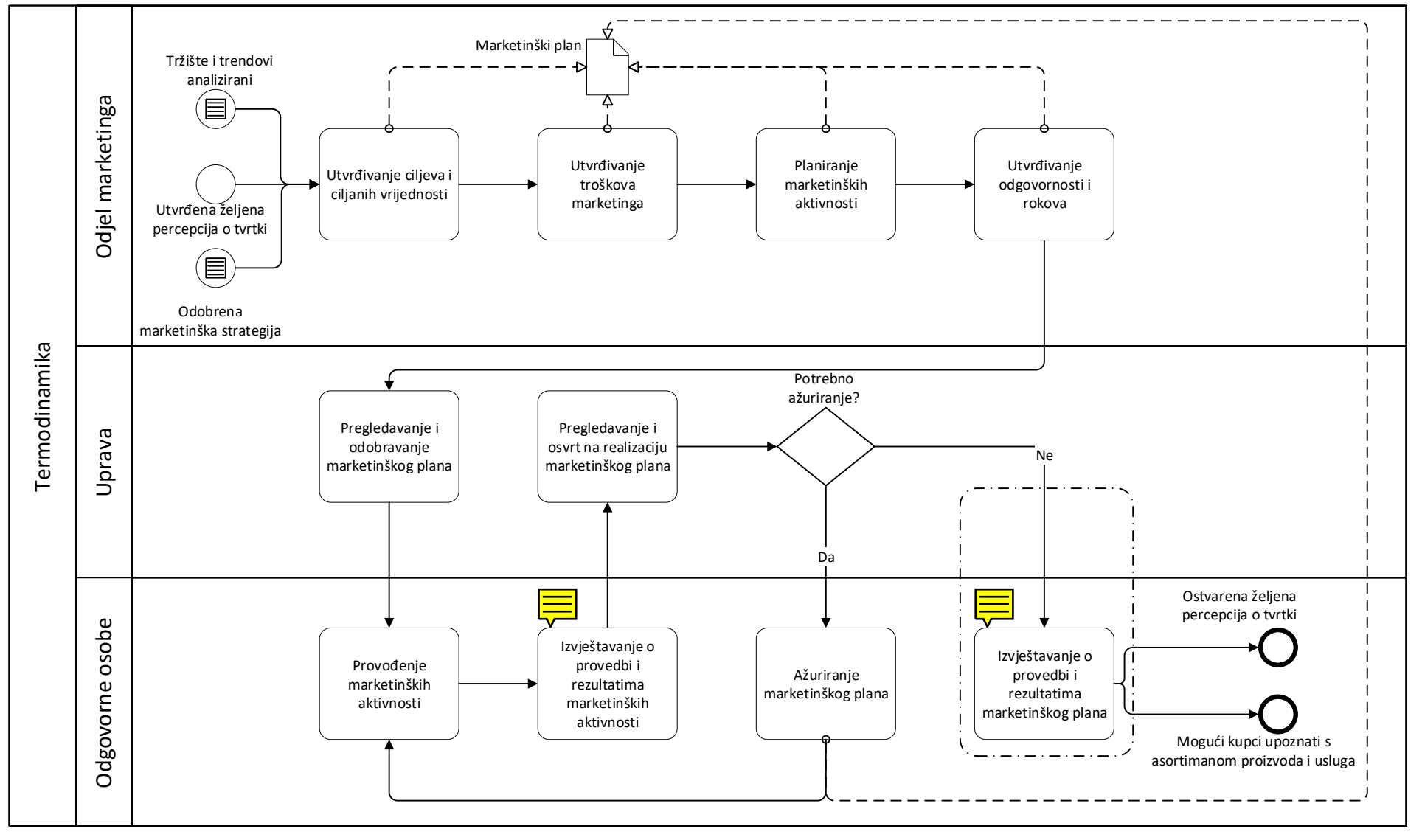

Termodinamika

Voditelji sektora

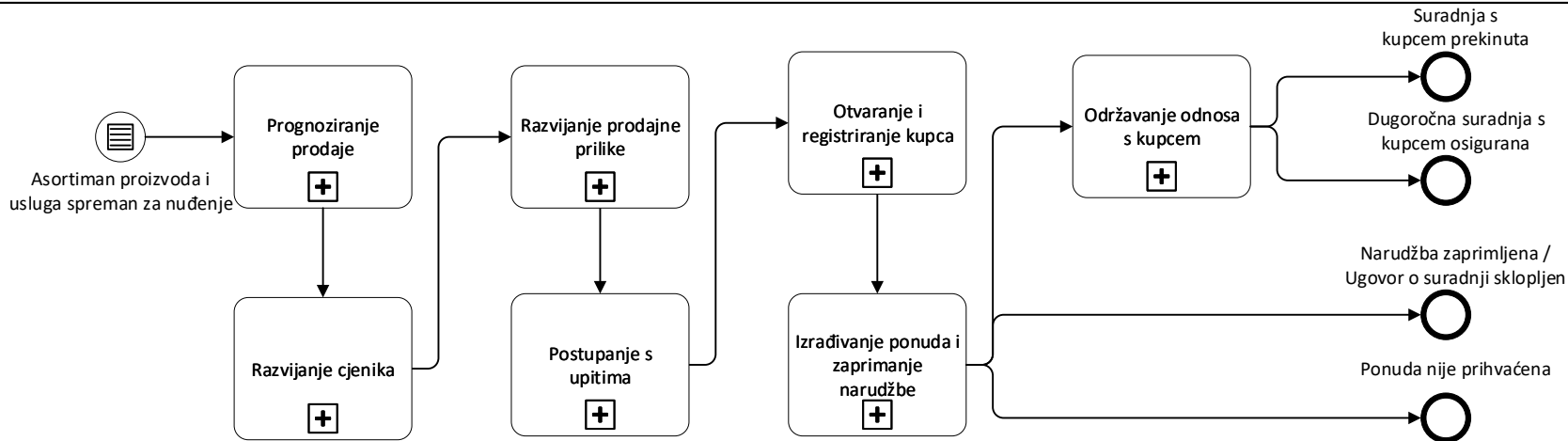



Prognoziranje prodaje

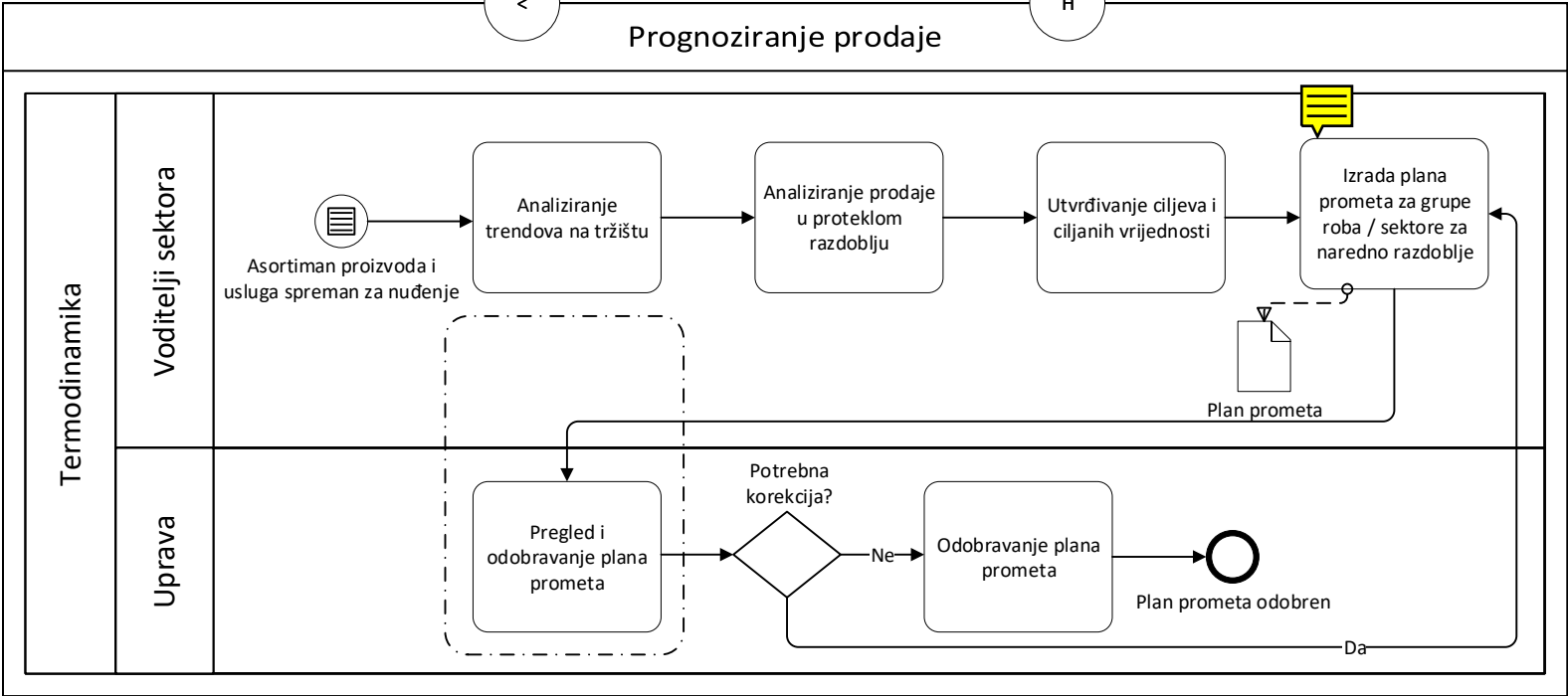

<

H

Razvijanje cjenika

Termodinamika

Voditelj robnih grupa

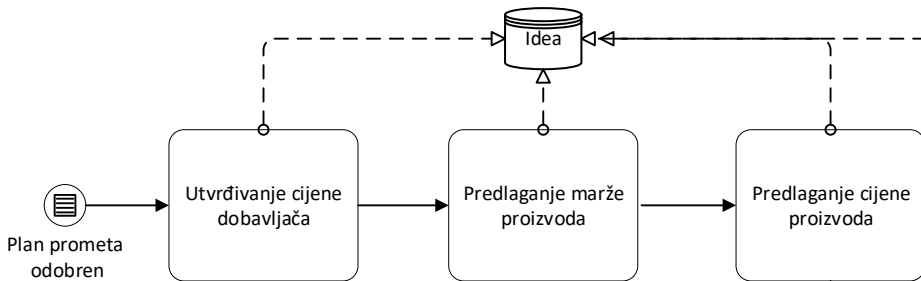

Voditelj sektora

Odobranje cijene
proizvodaOdobreni
cijenik



Razvijanje prodajne prilike

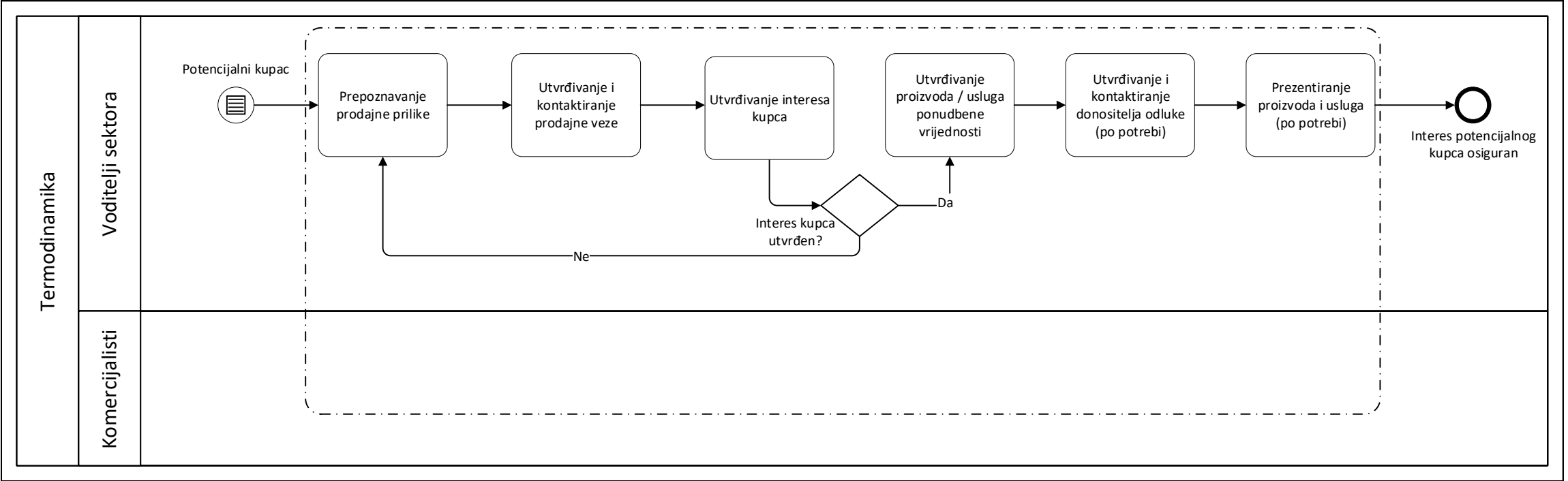

<

H

Postupanje s upitima

Termodinamika

Komerzijalisti

Interes
potencijalnog
kupca osiguran

Zaprimanje upita

Utvrđivanje
zahtjeva za
proizvod / usluguAnaliziranje
zahtjeva kupca i
mogućnost
realizacijeMoguće ispuniti
zahtjeve kupca?

Da

Mogućnost ispunjenja
zahtjeva kupca utvrđena

Ne

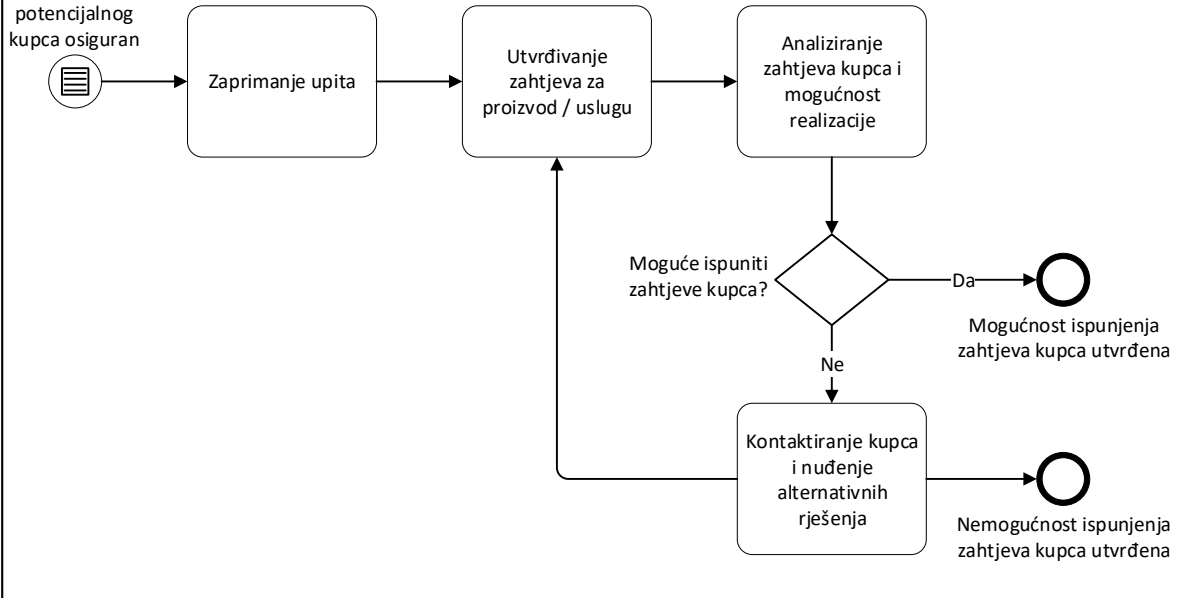
Kontaktiranje kupca
i nuđenje
alternativnih
rješenjaNemogućnost ispunjenja
zahtjeva kupca utvrđena



Otvaranje i registriranje kupca

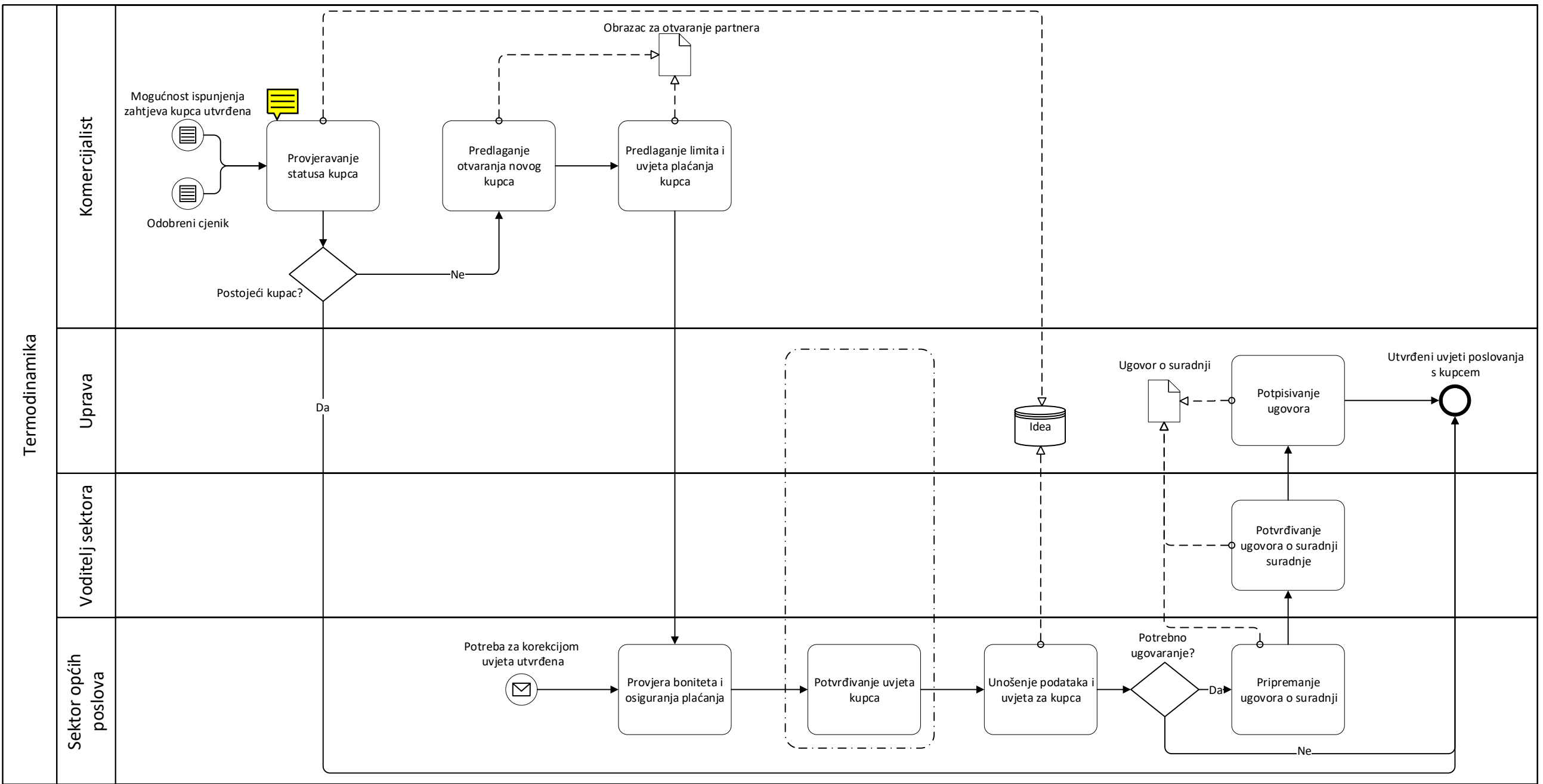



Izrađivanje ponuda i zaprimanje narudžbe

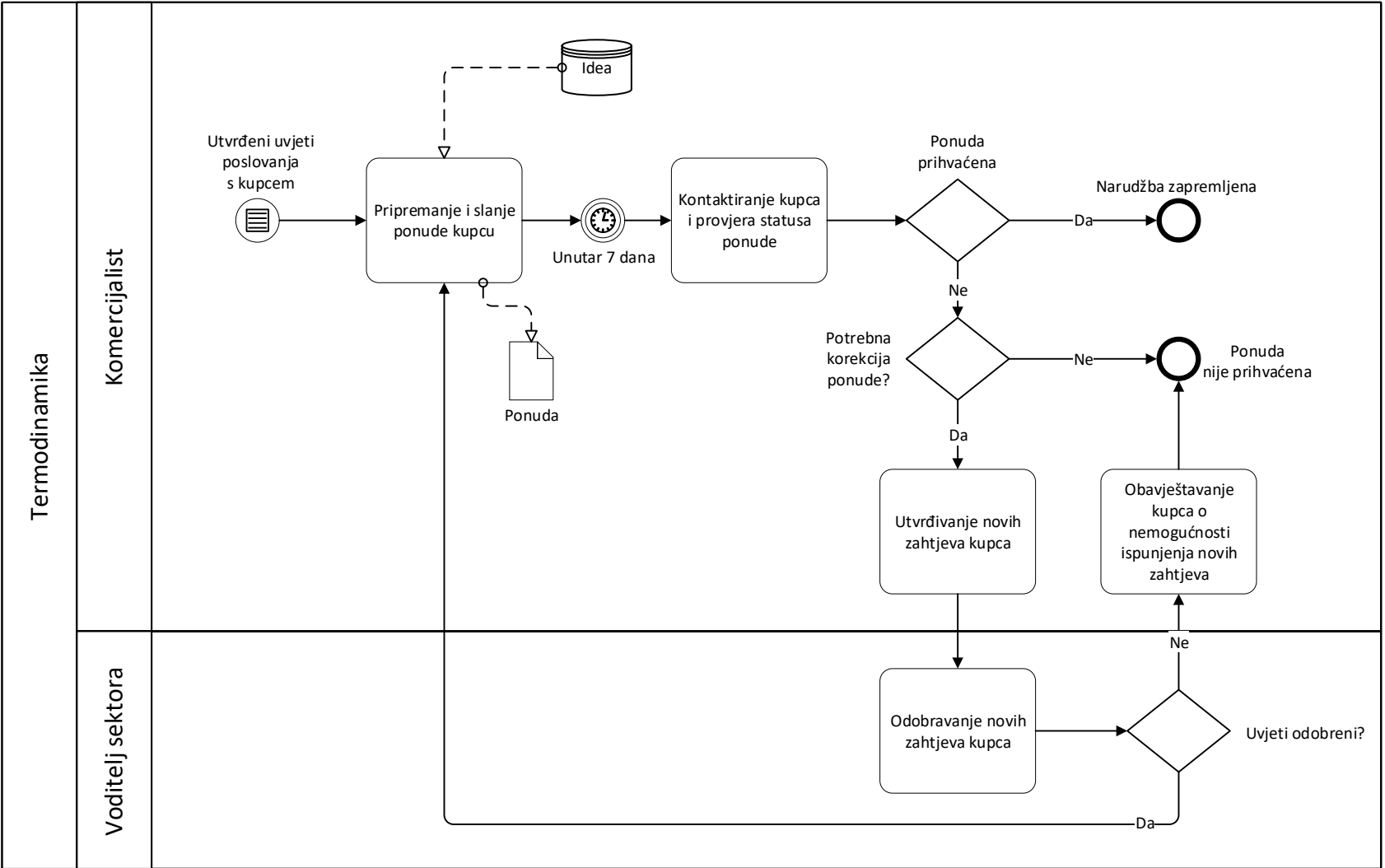

Održavanje odnosa s kupcem

Termodinamika

Komercijalista

Voditelj sektora

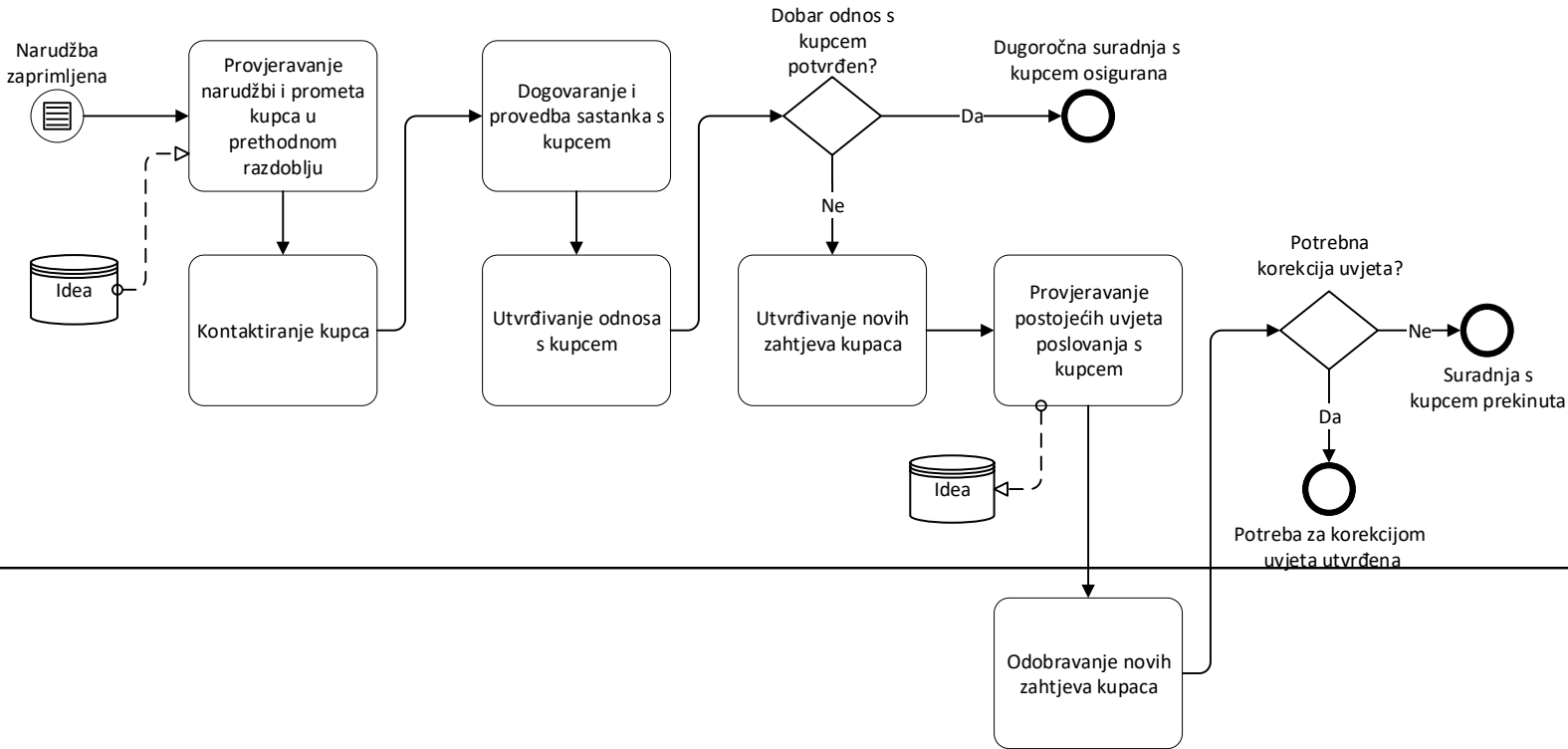



Izvršenje narudžbe kupca

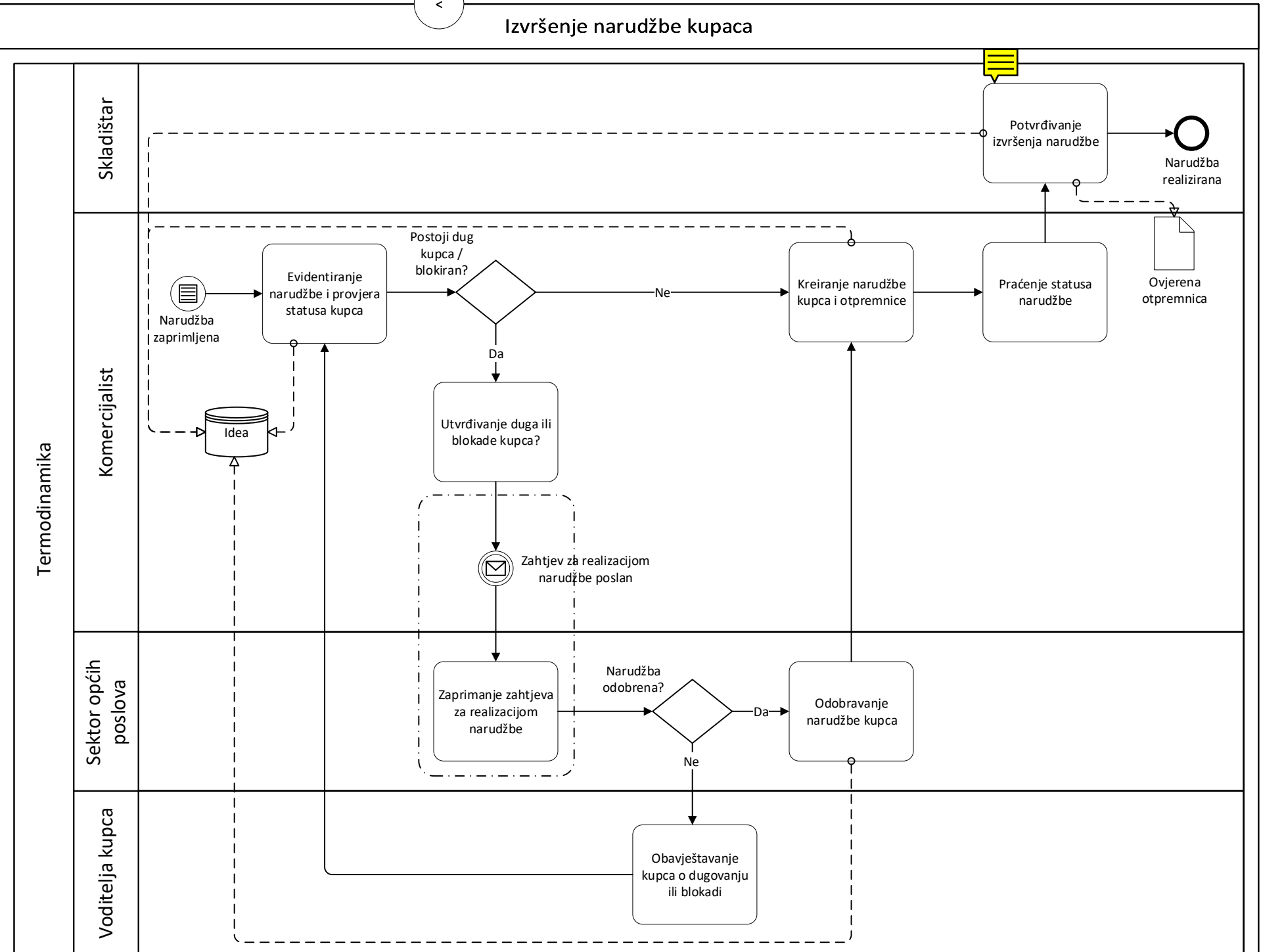



Upravljanje proizvodnjom

Termodinamika

Voditelj proizvodnje

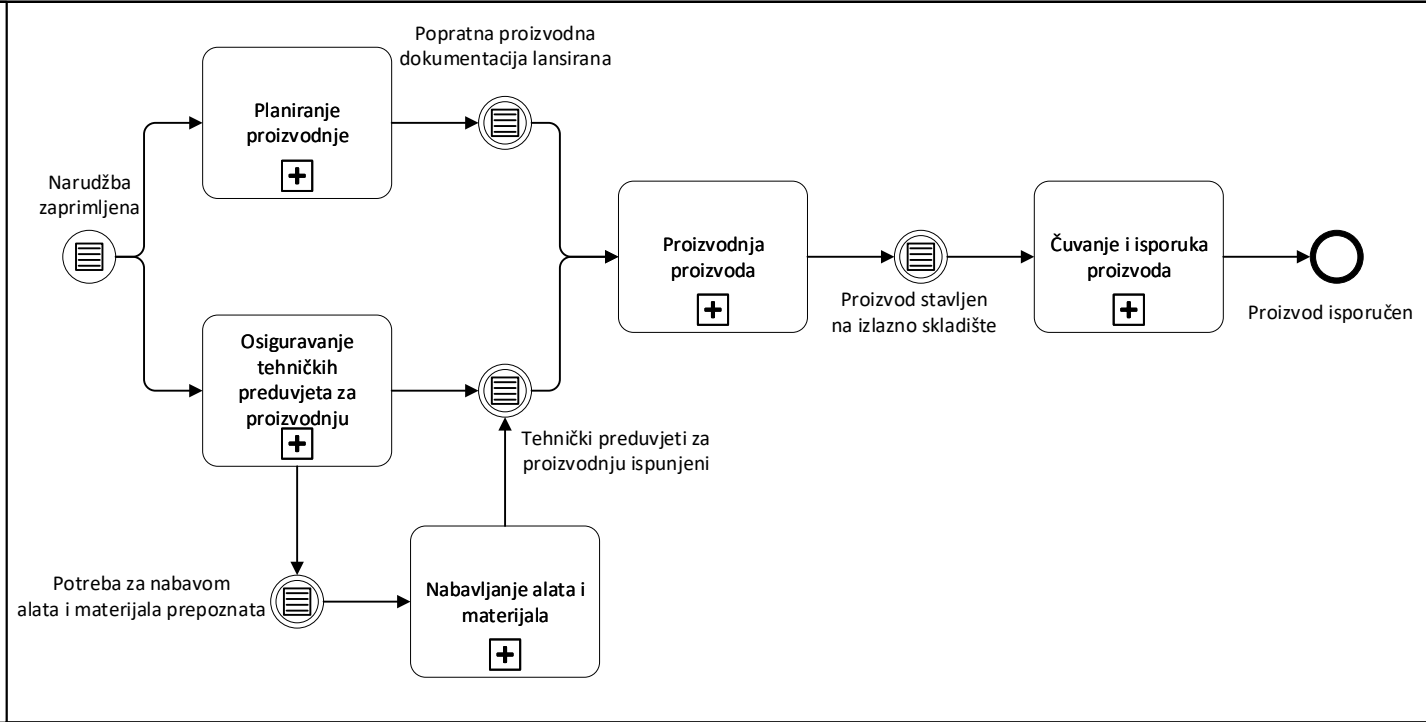



Planiranje proizvodnje

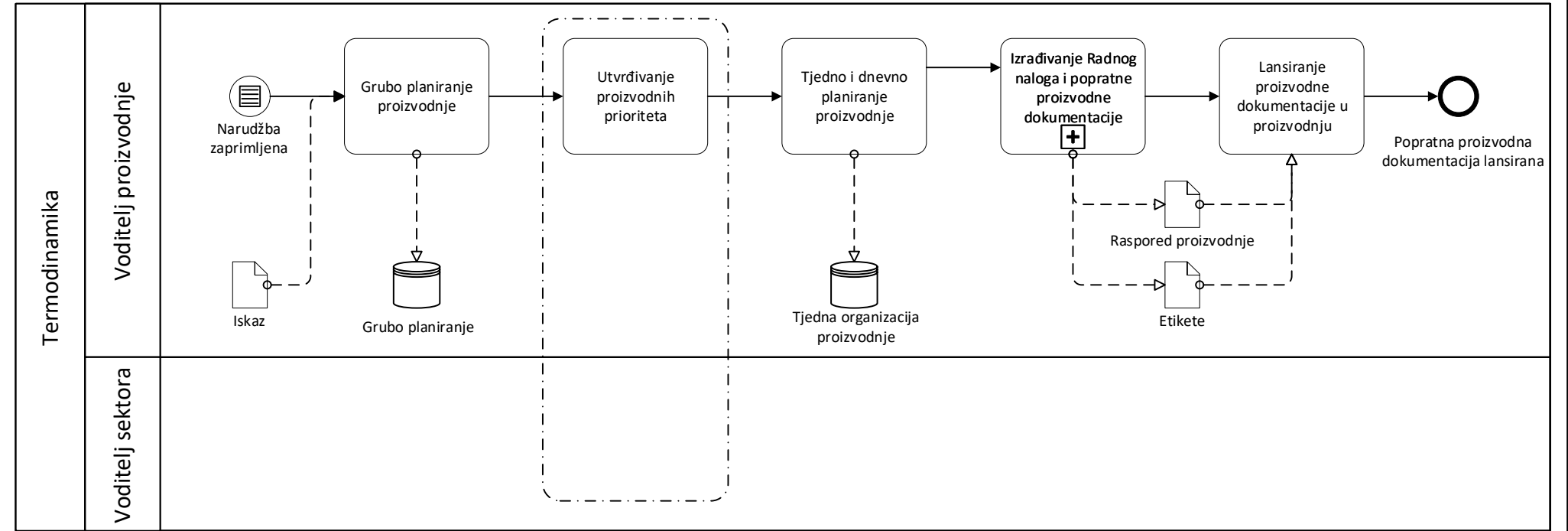



Izrađivanje Radnog naloga i popratne proizv. dokumentacije

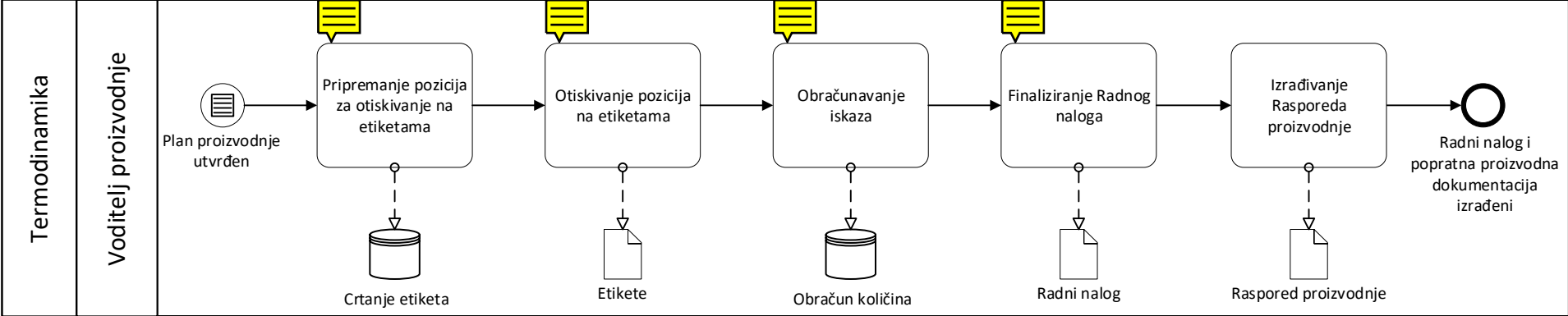

<

Osiguravanje tehničkih preuvjeta za proizvodnju

H

Termodinamika

Voditelj proizvodnje

Narudžba
zaprimljena

Iskaz

Provjeravanje
potpunosti i
razumljivosti iskazaIskaz potpun i
razumljiv?

Da

Ne

Prikupljanje
dodatnih
informacijaProvjera
dostupnosti alata i
materijalaAlati i materijali
dostupni?

Da

Ne

Potreba za nabavom
alata i materijala prepoznataTehnički preuvjeti za
proizvodnju ispunjeni

Proizvodnja proizvoda

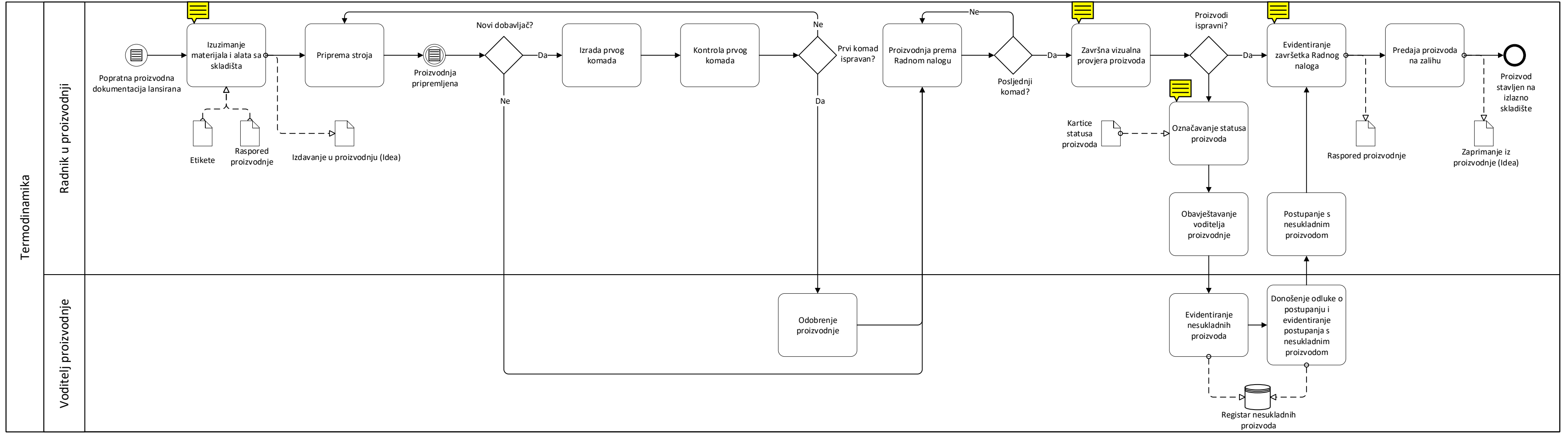



Čuvanje i isporuka proizvoda

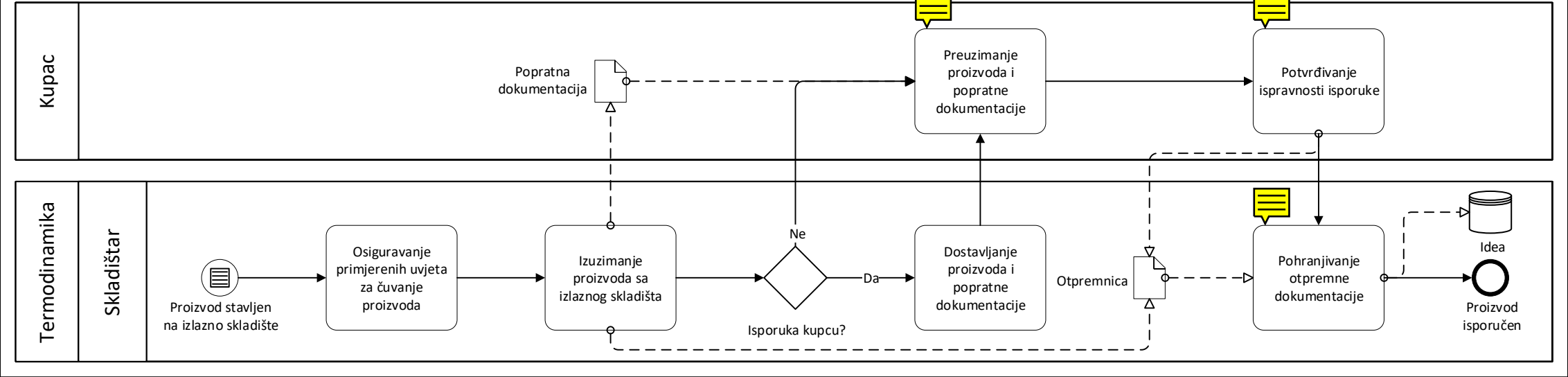

Nabavljanje alata i materijala

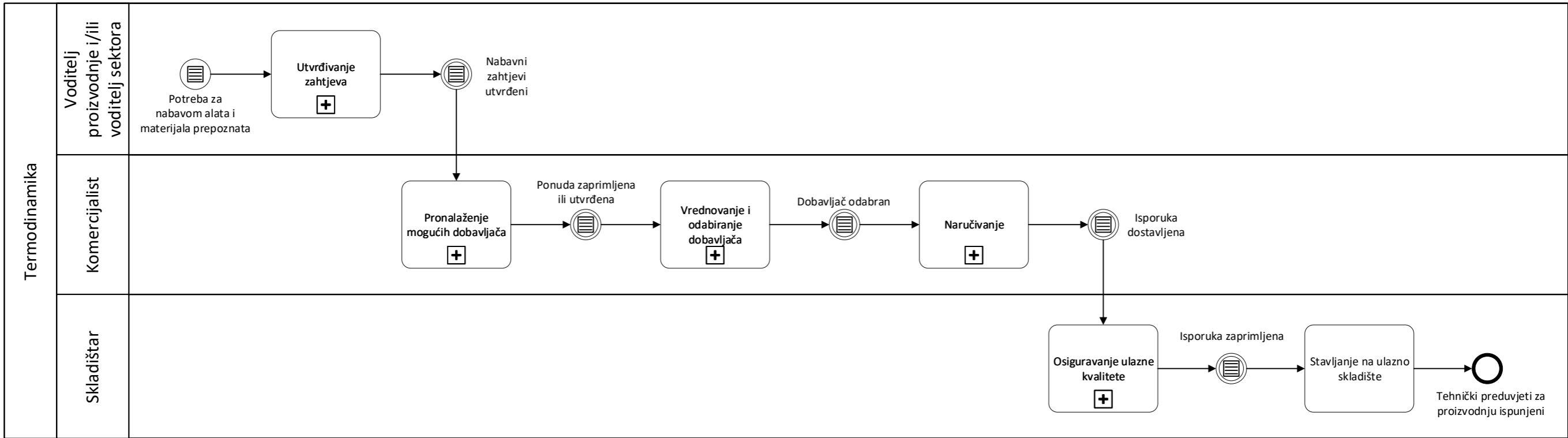



Utvrđivanje zahtjeva

Termodinamika

Voditelj proizvodnje i/ili voditelj sektora

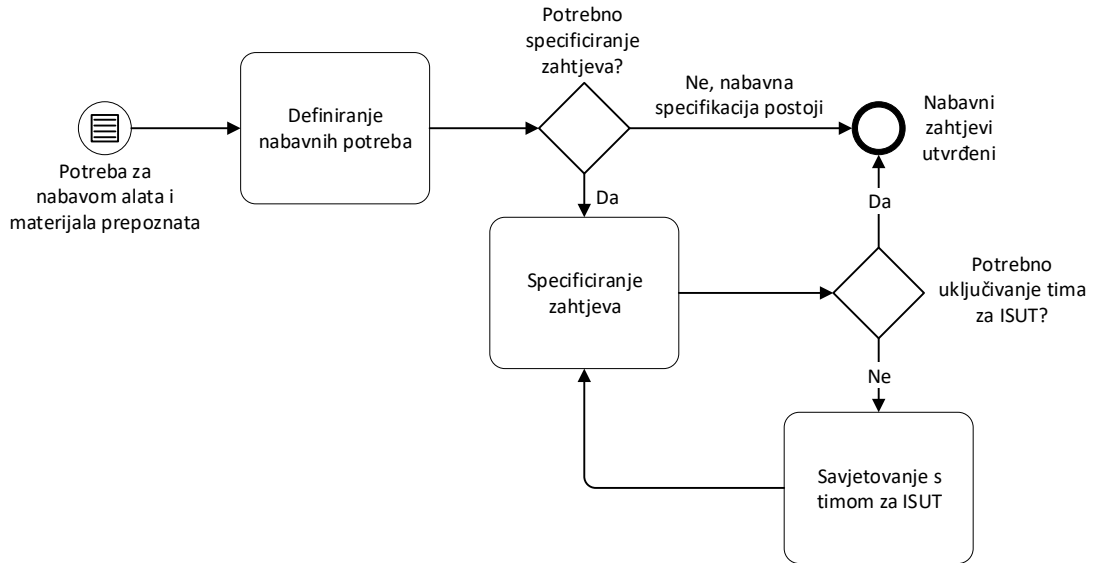



Pronalaženje mogućih dobavljača

Termodinamika

Komercijalist

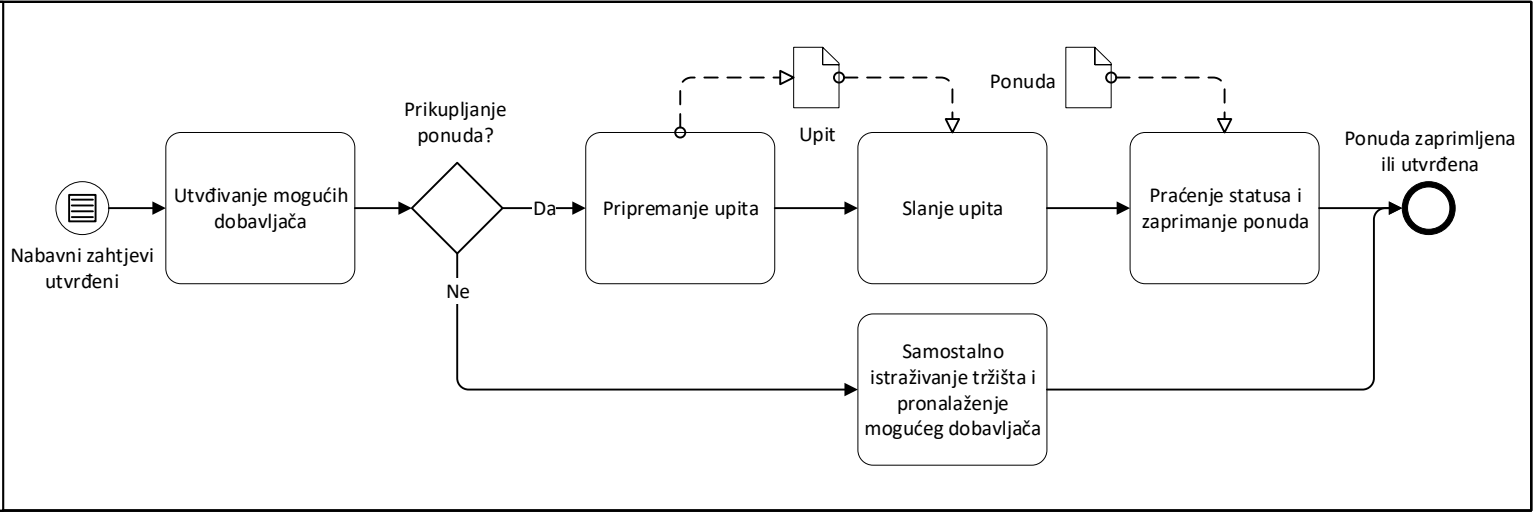



Vrednovanje i odabiranje dobavljača

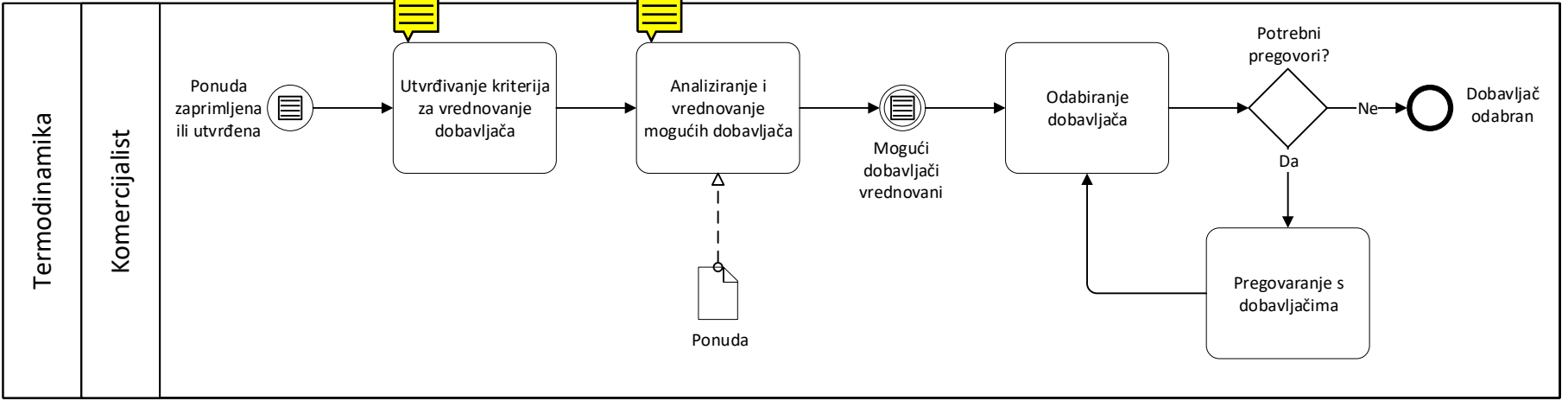

Termodinamika

Komercijalist

Ponuda zaprimljena ili utvrđena

Utvrđivanje kriterija za vrednovanje dobavljača

Analiziranje i vrednovanje mogućih dobavljača

Mogući dobavljači vrednovani

Odabiranje dobavljača

Potrebni pregovori?

Pregovaranje s dobavljačima

Dobavljač odabran

Ponuda



Naručivanje

Termodinamika

Komercijalist

Dobavljač odabran



Izrađivanje narudžbenice

Slanje narudžbenice dobavljaču

Praćenje statusa isporuke

Isporuka dostavljena

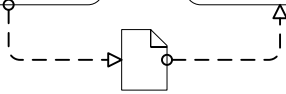

Narudžbenica



Osiguravanje ulazne kvalitete

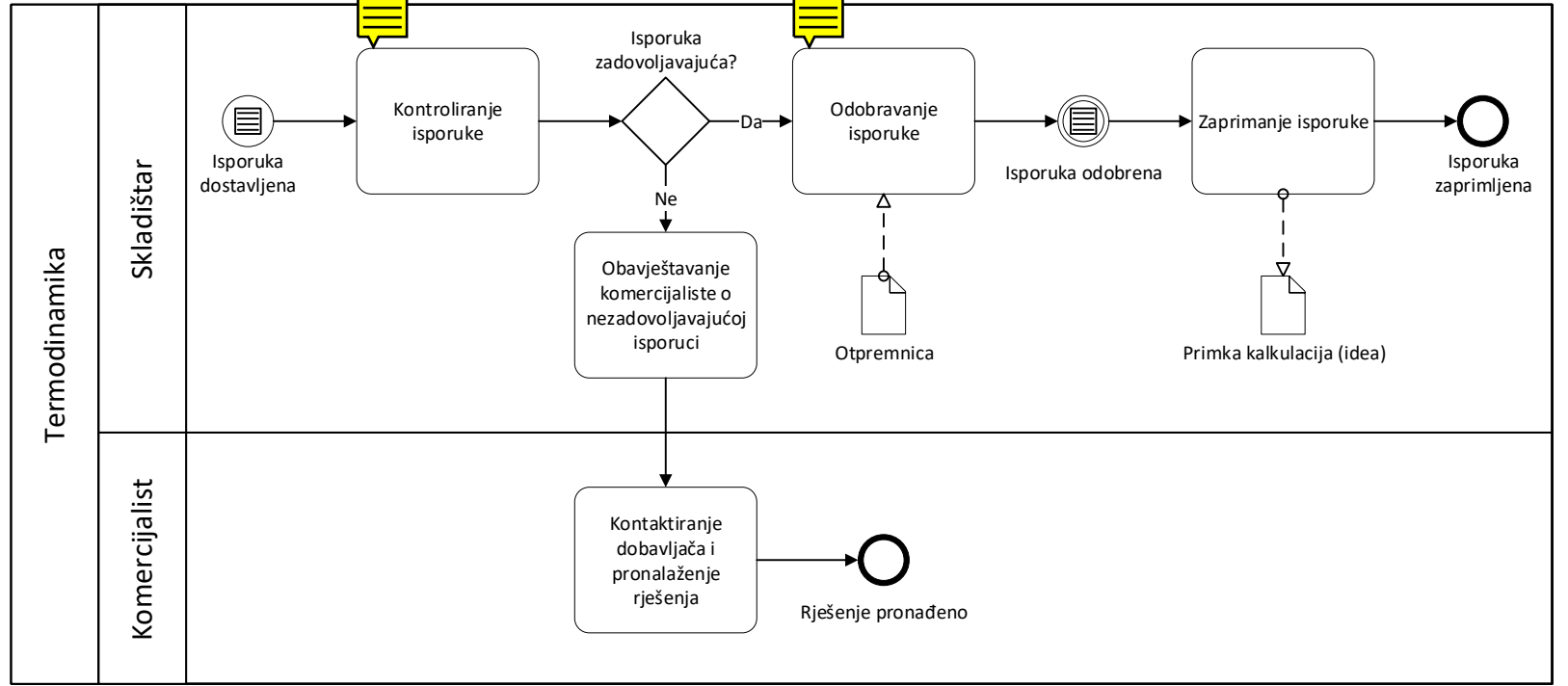

Termodinamika

Skladištar

Komerrijalist

Upravljanje post prodajnim aktivnostima

Termodinamika

Voditelji sektora

Narudžba realizirana



Postupanje s reklamacijama kupaca



Povrat robe



Postupanje s garancijama



Ispitivanje zadovoljstva kupaca



Zadovoljstvo kupca osigurano

Prijedlog za poboljšanjem prepoznat

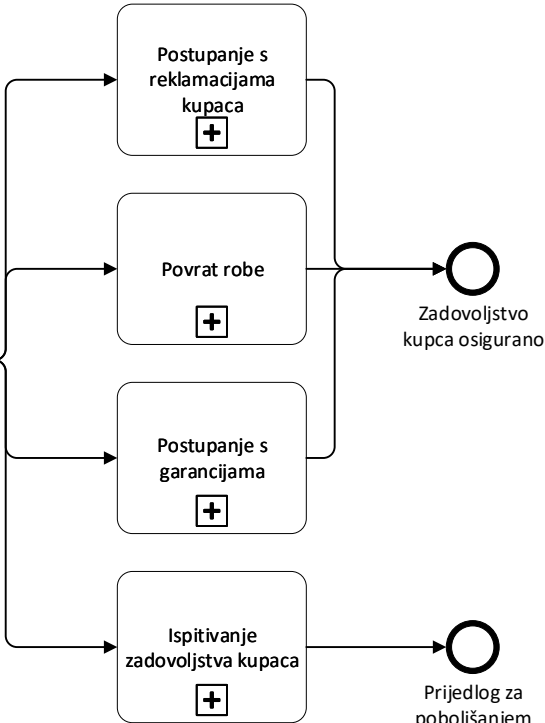

Postupanje s reklamacijama

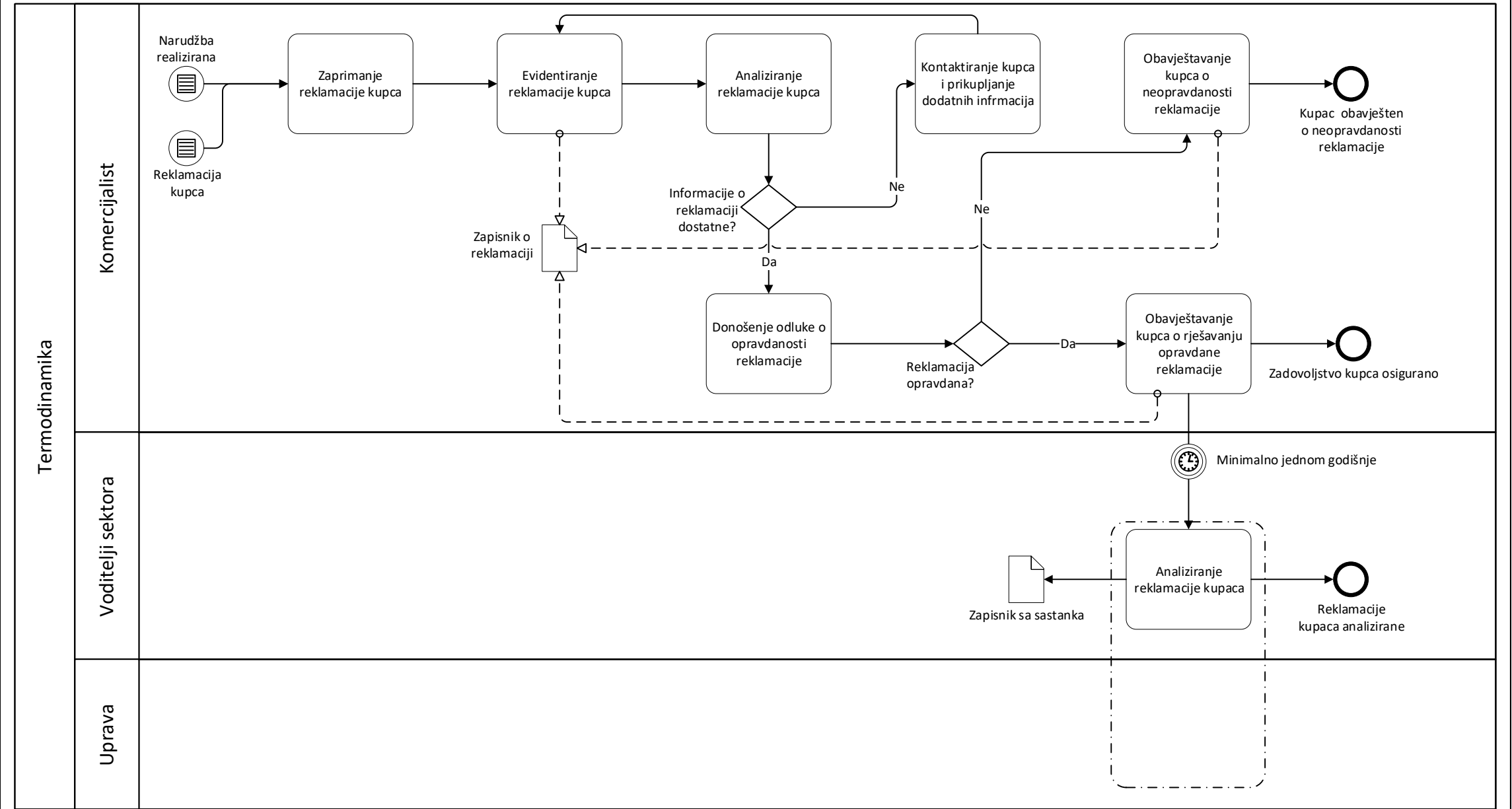

Povrat robe

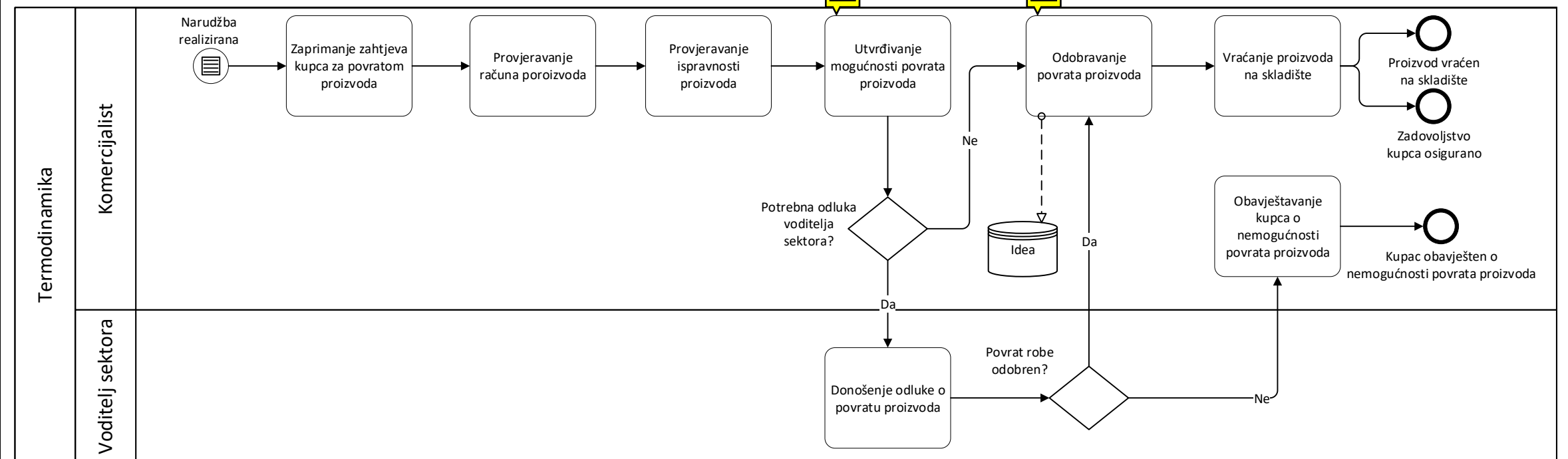

Postupanje s garancijama

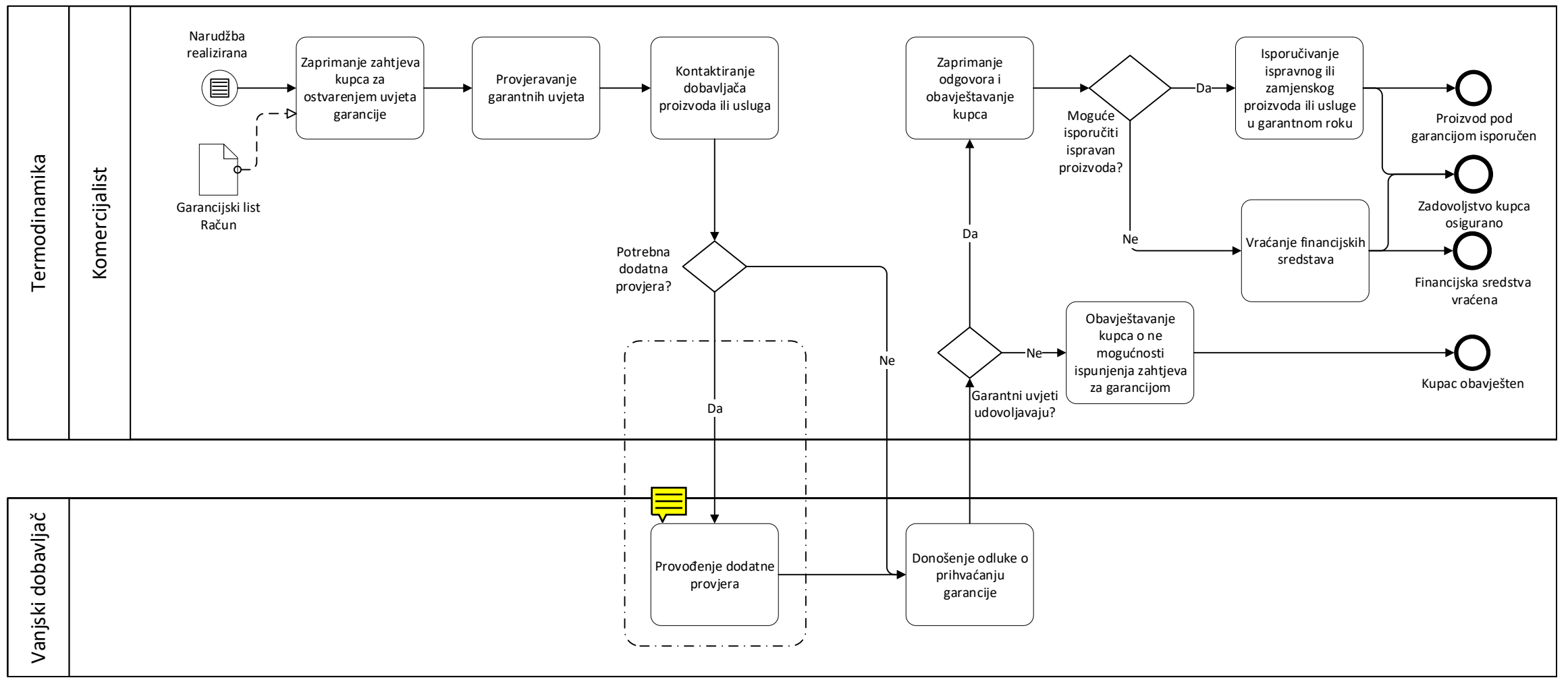

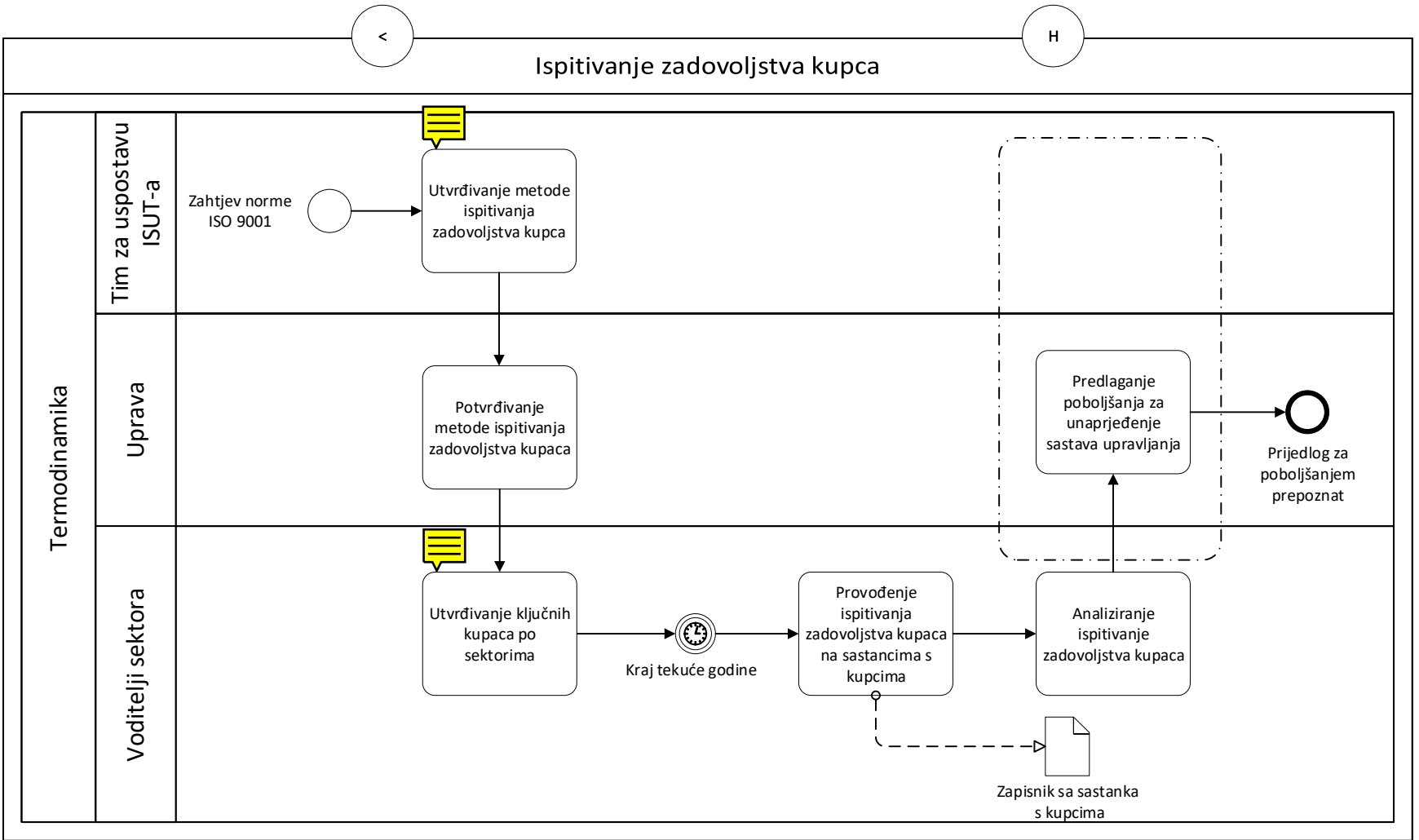



Upravljanje ljudskim resursima

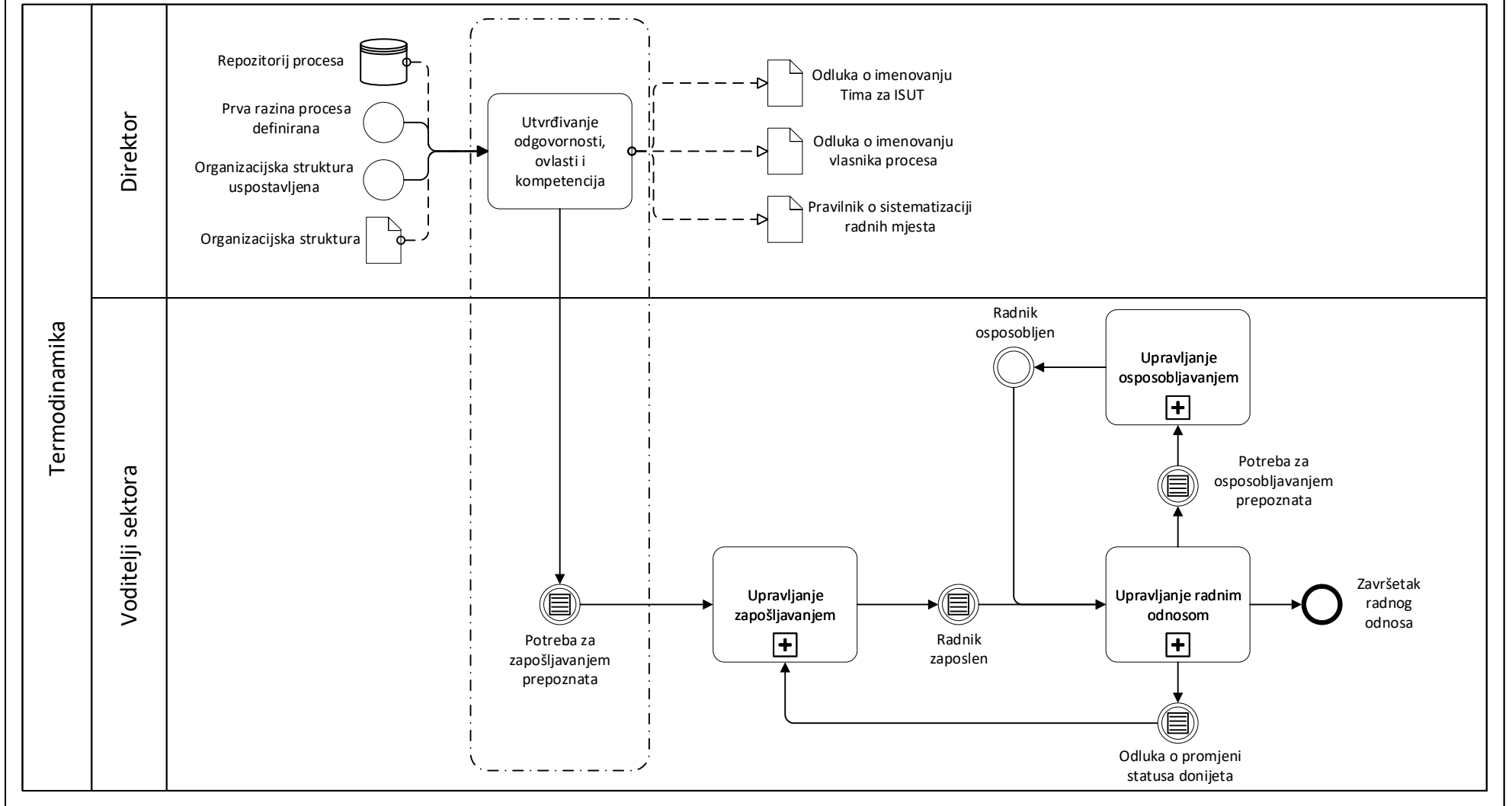

<

H

Upravljanje zapošljavanjem

Termodinamika

Voditelj sektora

Potreba za
zapošljavanjem
prepoznataIniciranje
zapošljavanjaKomisija za
zapošljavanjeProvođenje
seleksijskog
postupka

Uprava

Ugovaranje radnika

Radnik
zaposlen



Iniciranje zapošljavanja

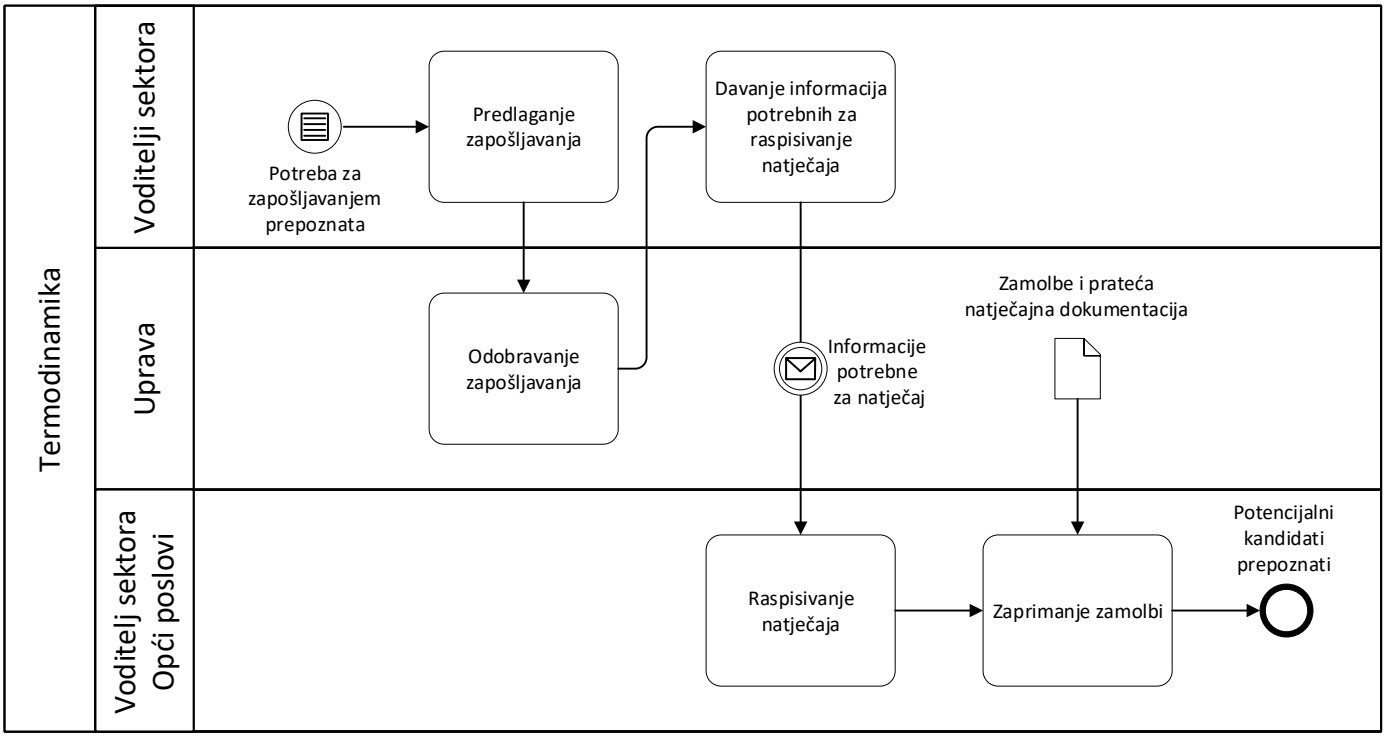



Provođenje selekcijskog postupka

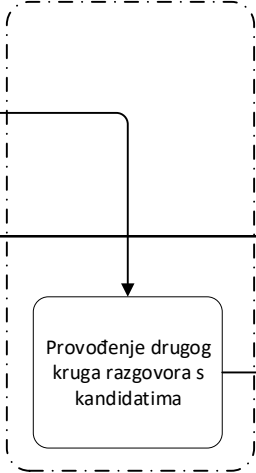
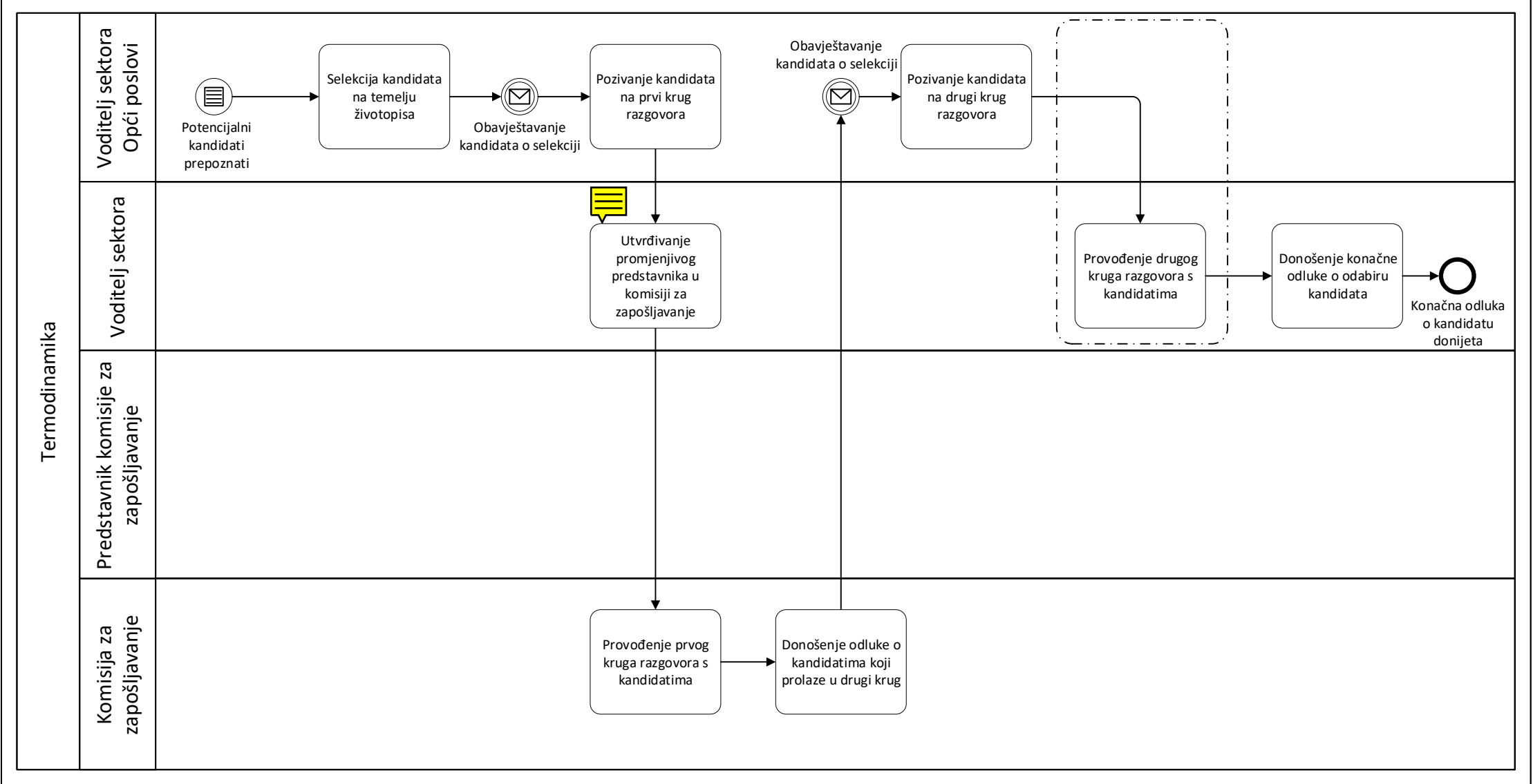



Ugovaranje radnika

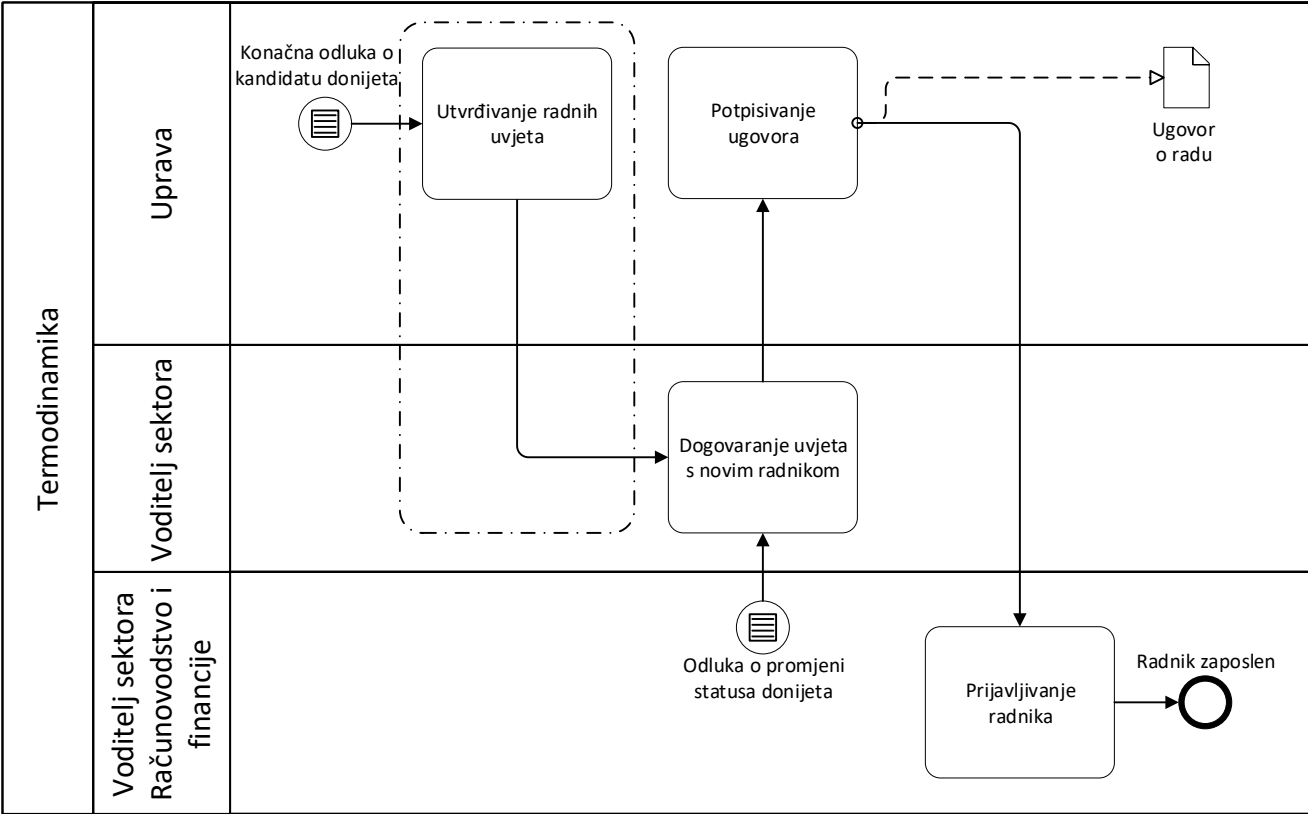



Upravljanje radnim odnosom

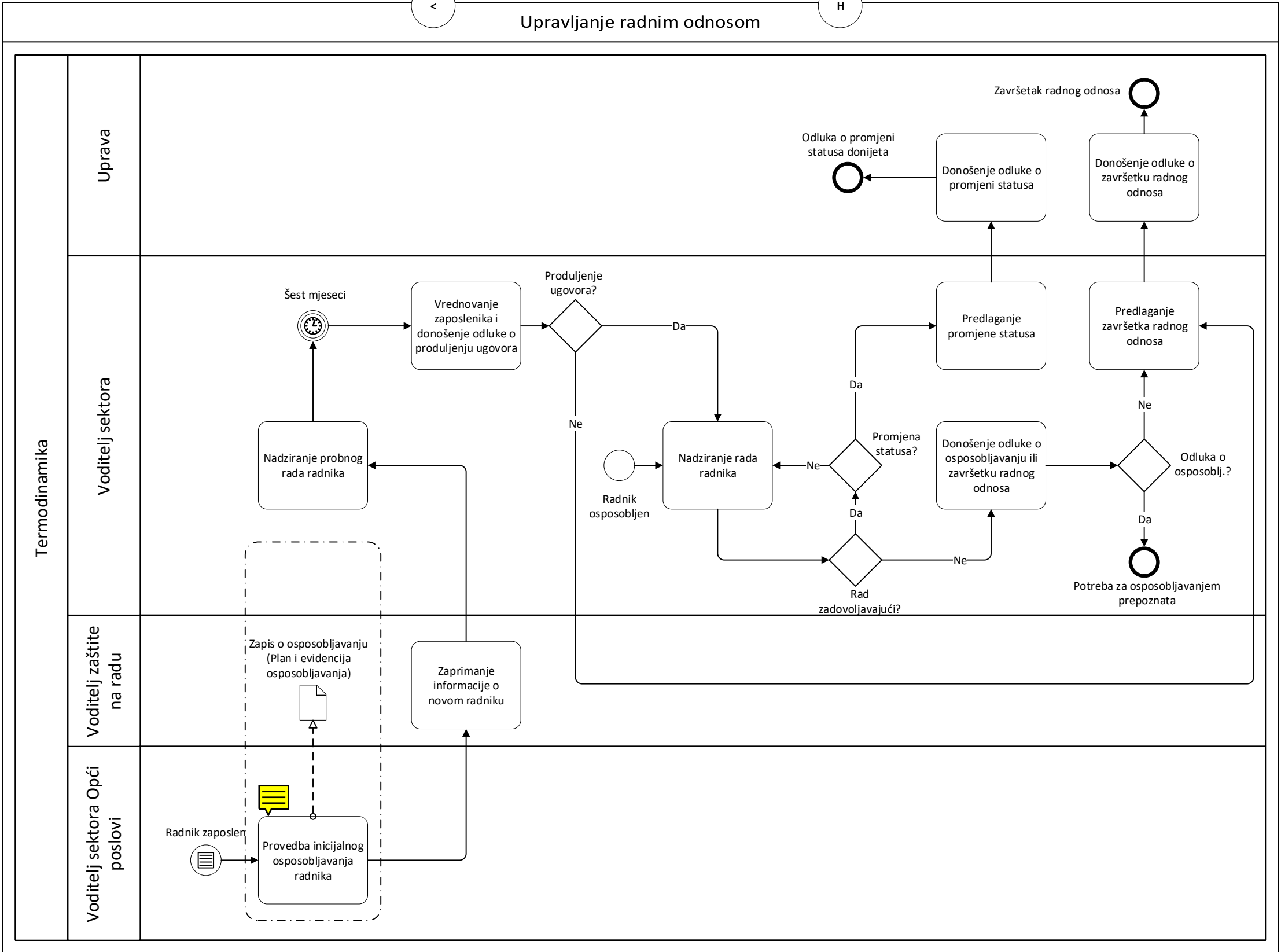

Upravljanje osposobljavanjem

Termodinamika

Uprava

Odjel općih poslova

Voditelj sektora

Radnik

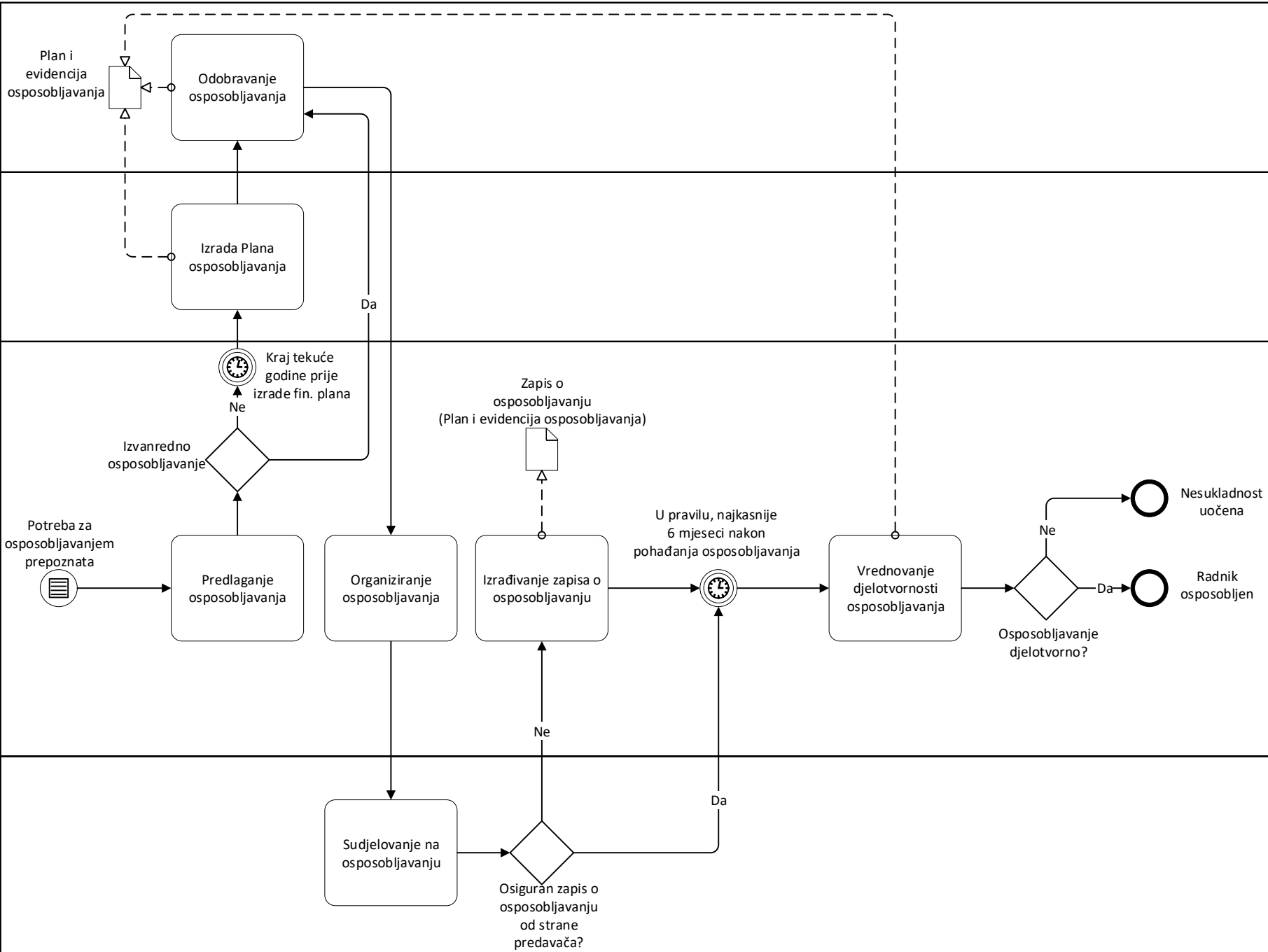

Upravljanje materijalnim resursima

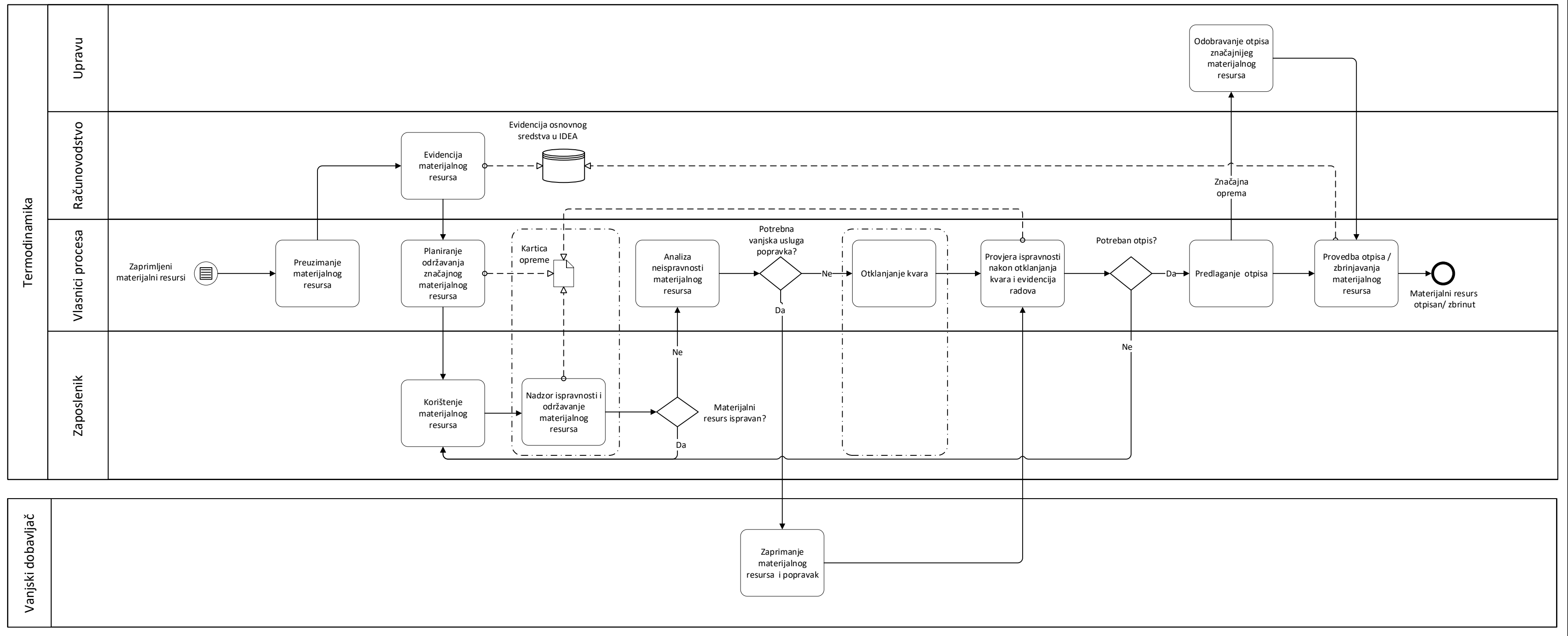

Upravljanje IKT-om

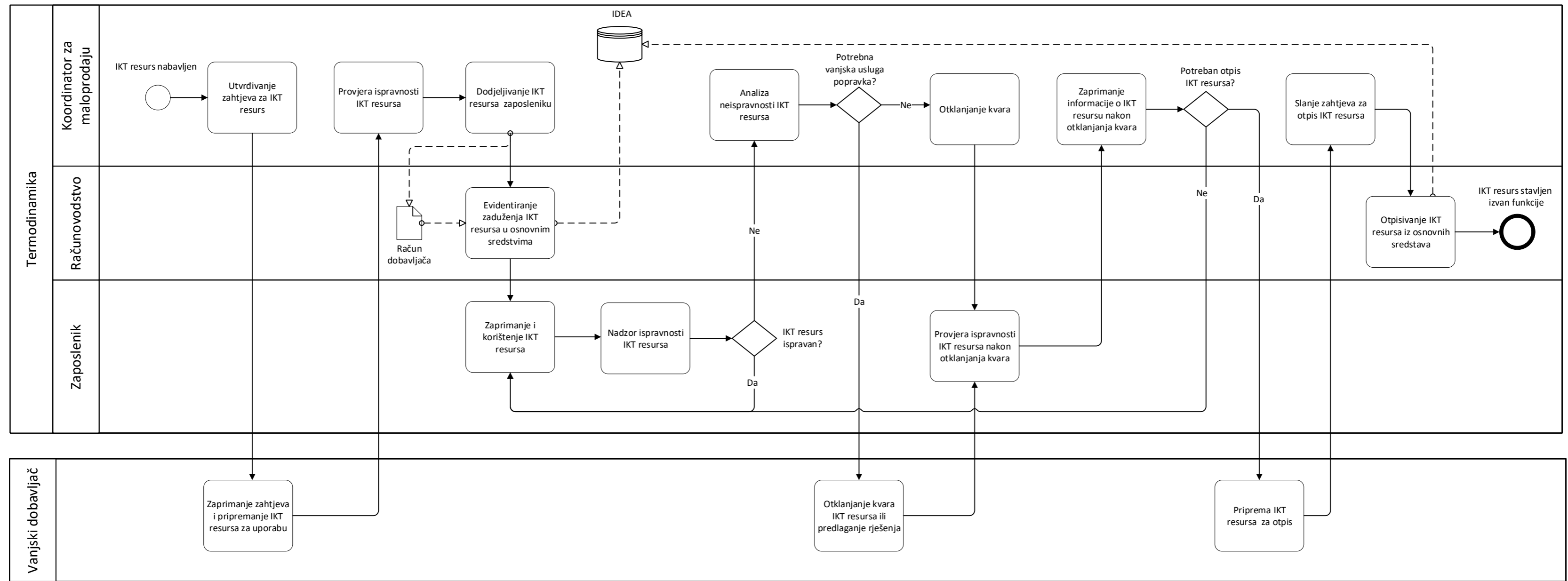



Upravljanje rizicima i usklađenošću

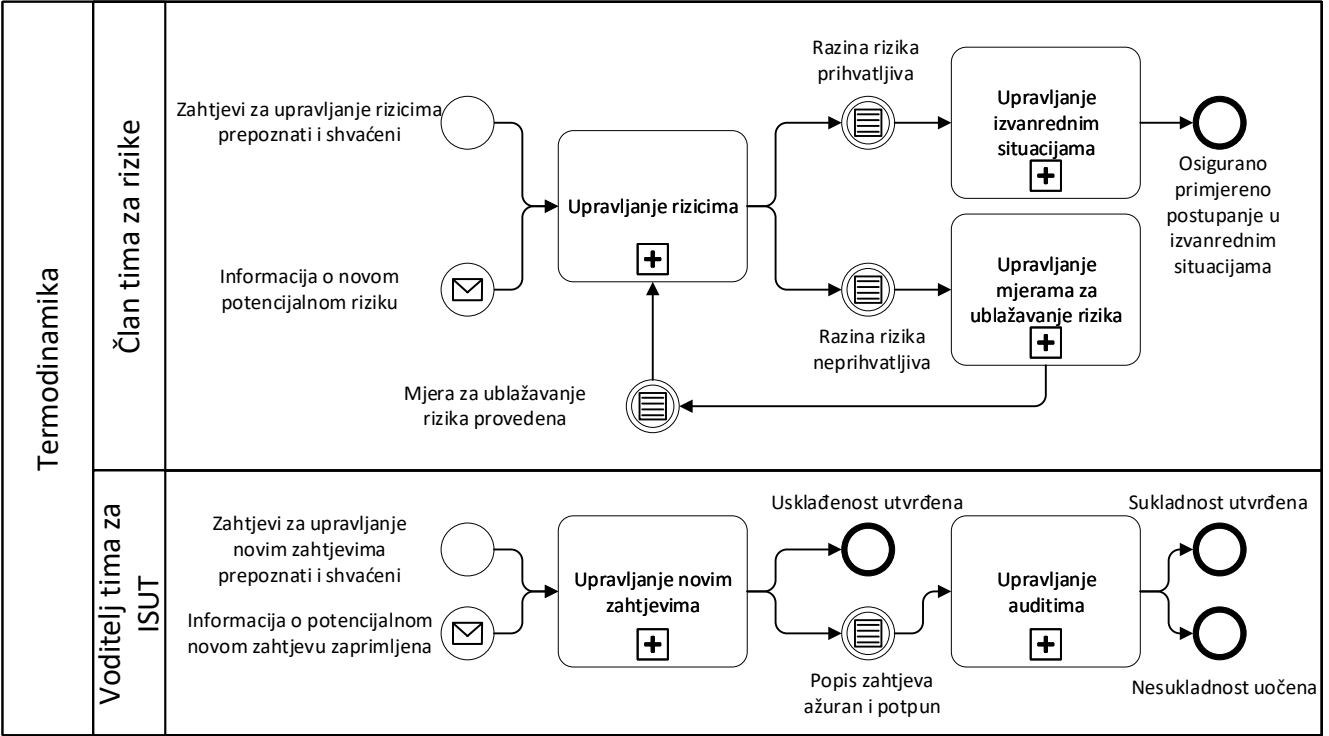



Upravljanje rizicima

Termodinamika

Član tima za rizike

Vlasnici procesa

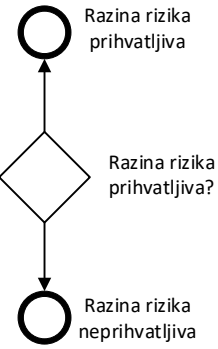
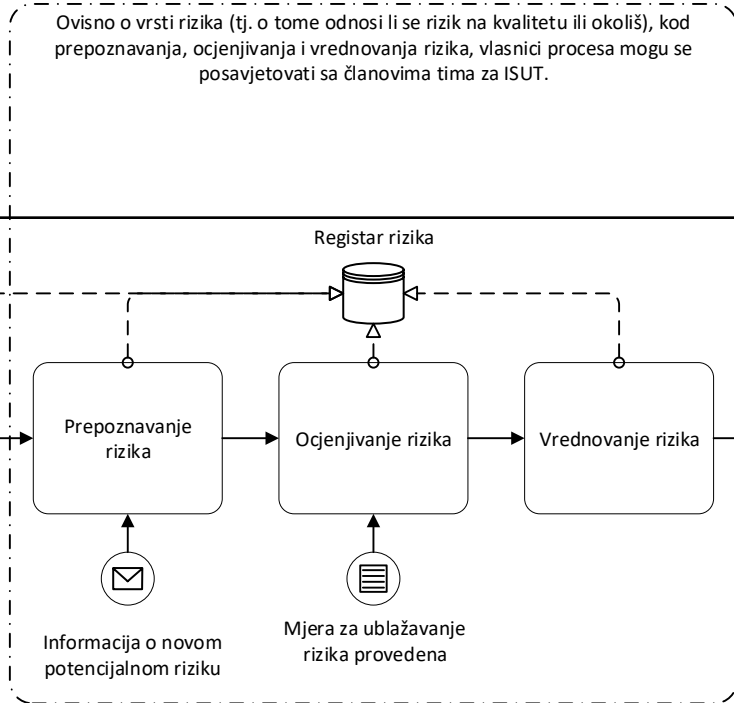
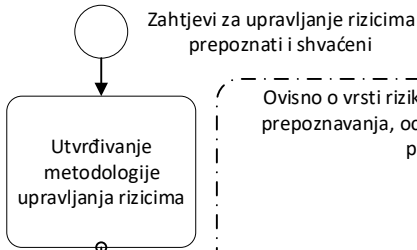



Upravljanje mjerama za ublažavanje rizika

Termodinamika

Član tima za rizike

Voditelj sektora

Radnik odgovoran
za provođenje
mjera

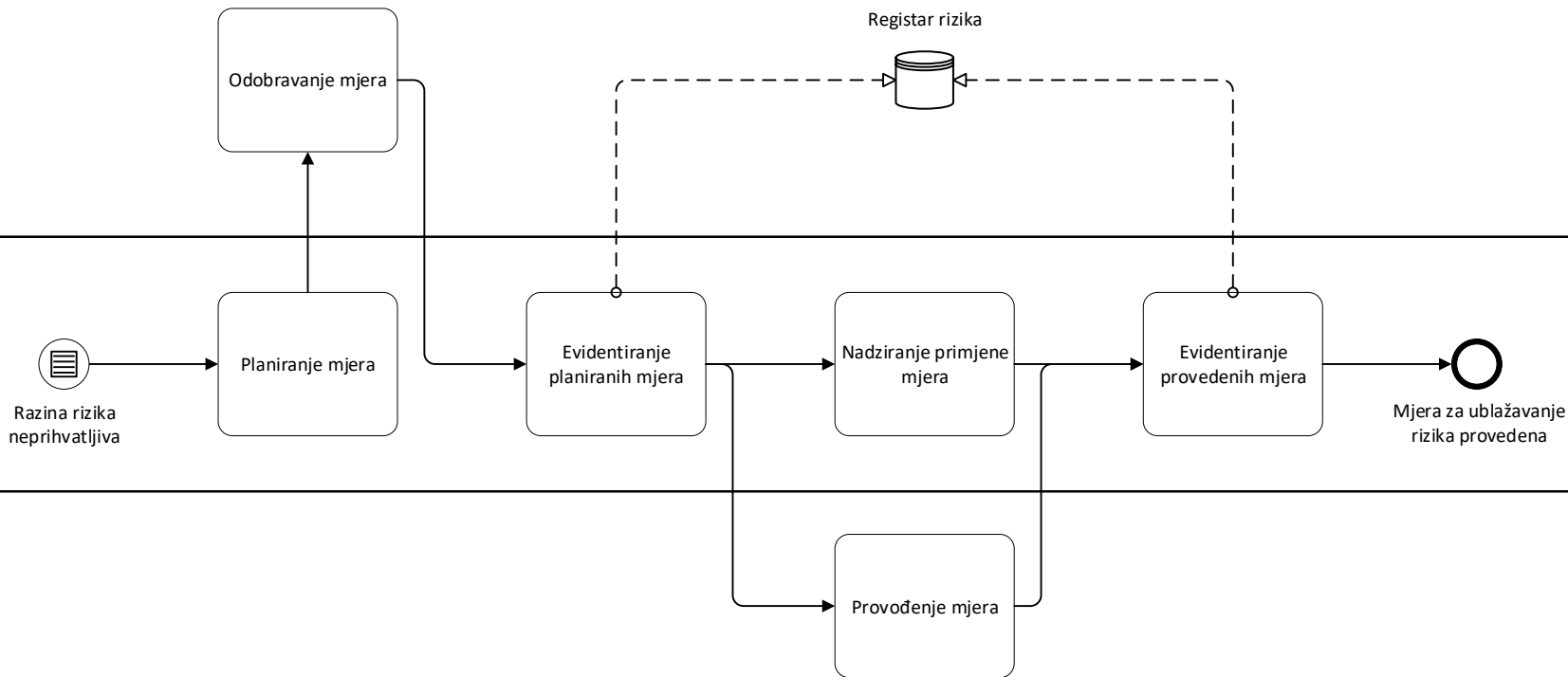



Upravljanje izvanrednim situacijama

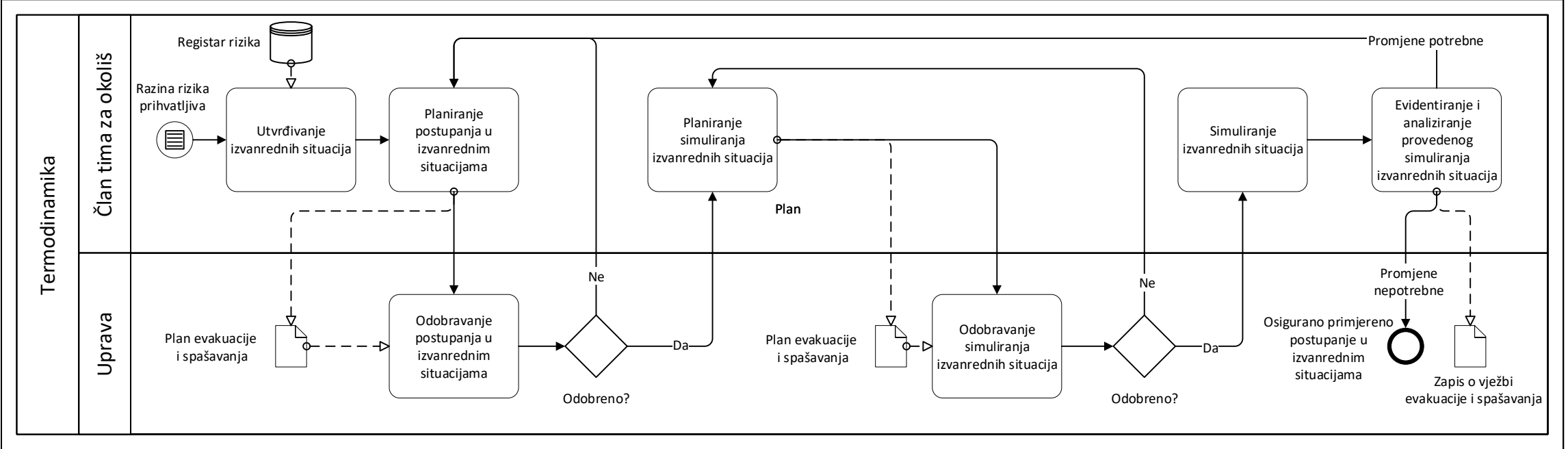



Upravljanje novim zahtjevima

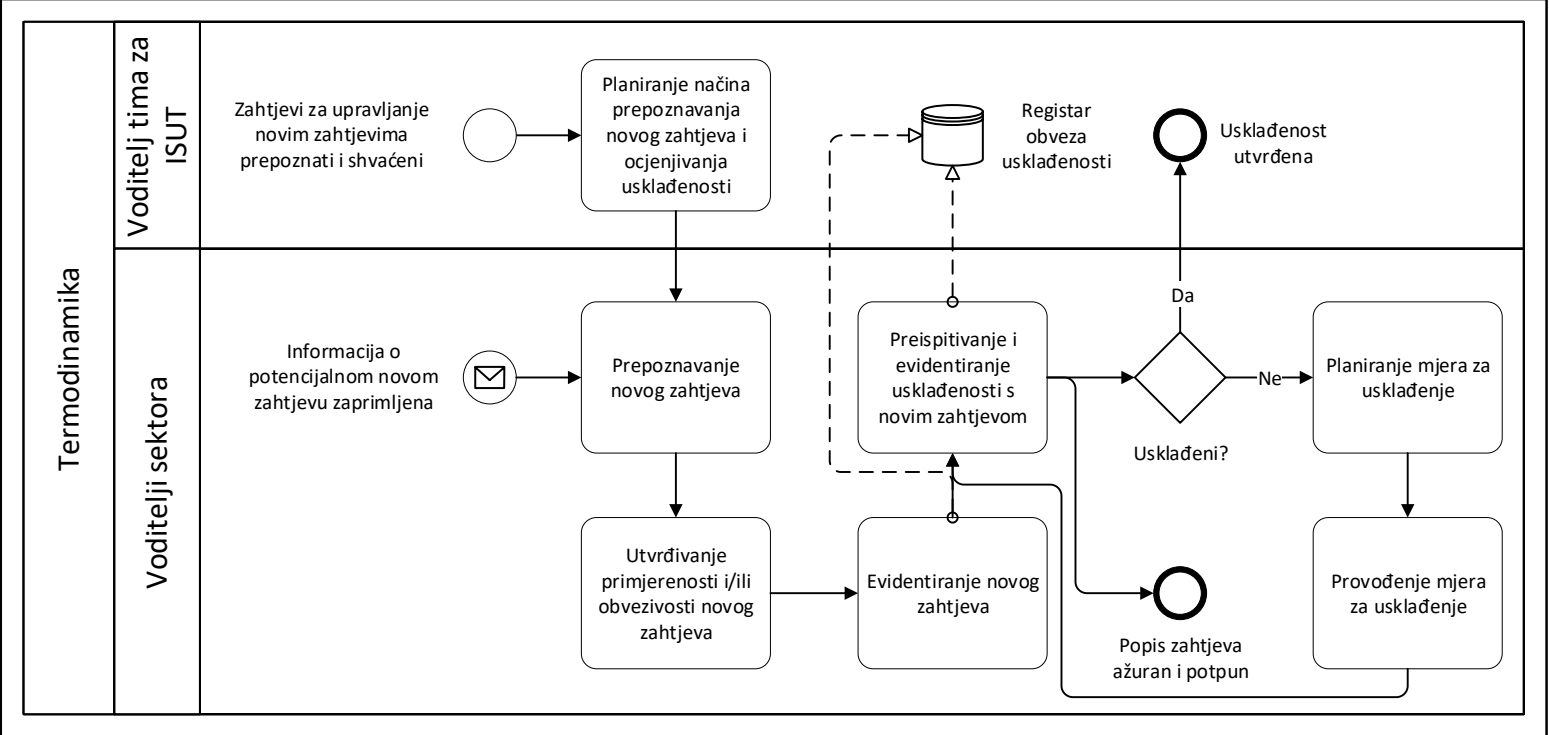



Upravljanje auditima

Termodinamika

Voditelj tima za ISUT-a

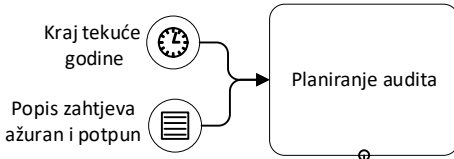

Uprava

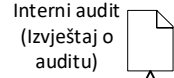
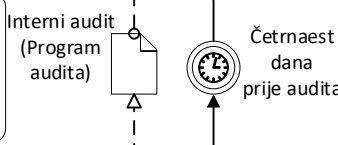
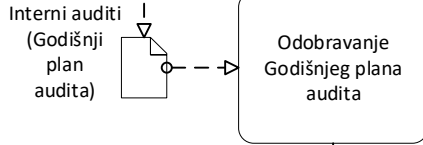

Voditelj auditorskog tima

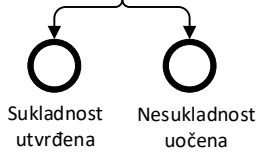
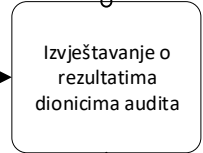
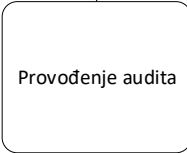
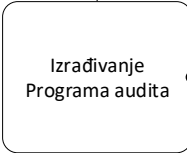

Članovi auditorskog tima

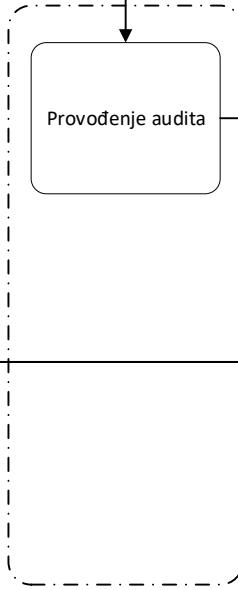



Upravljanje dokumentiranim informacijama

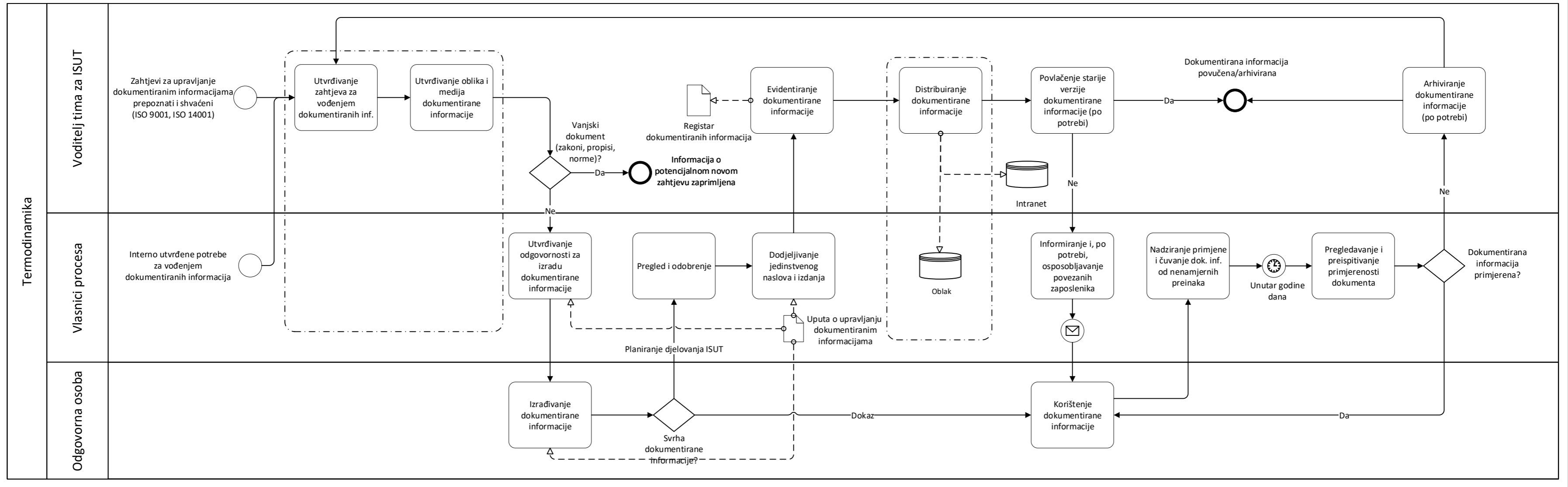

Upravljanje procesima

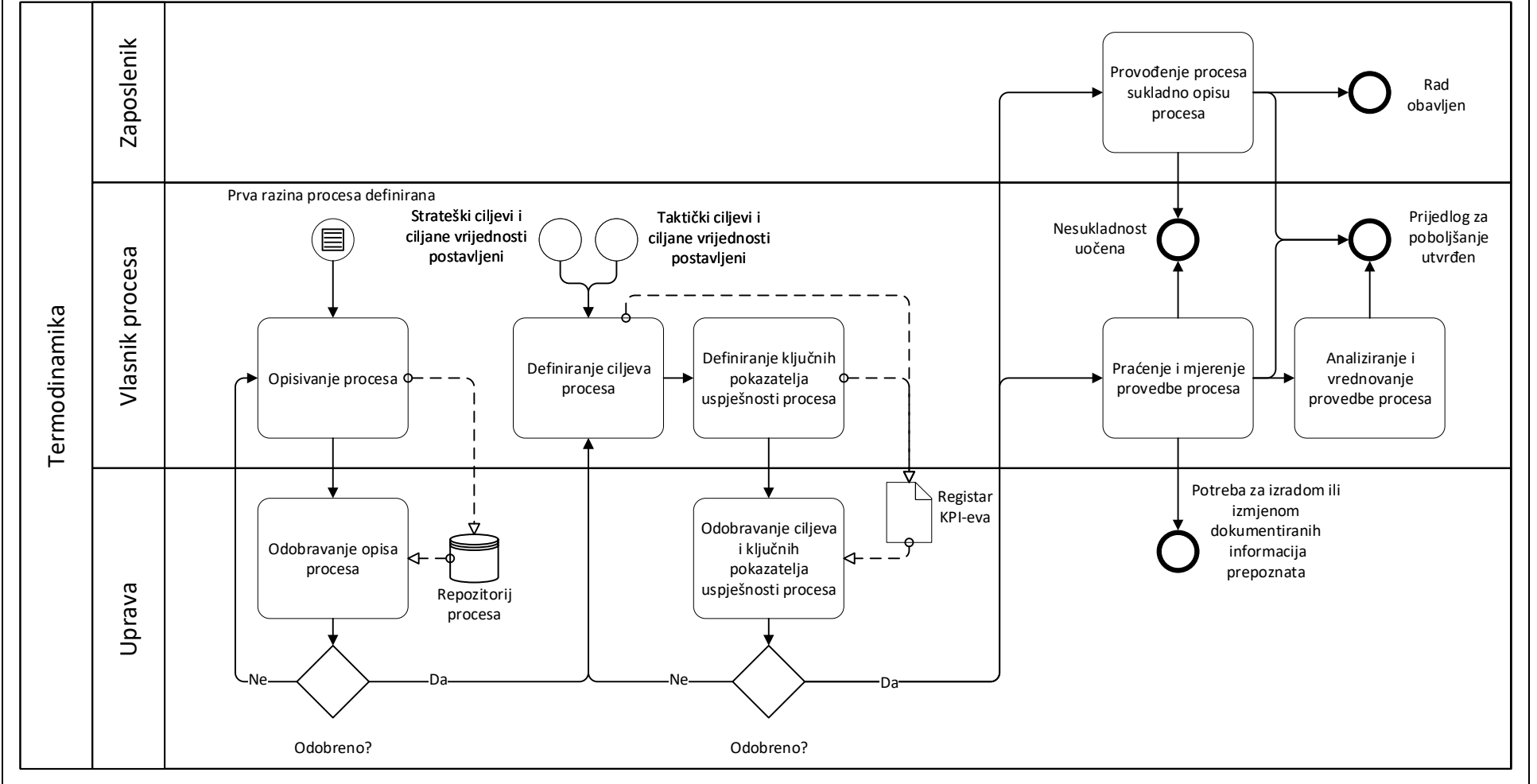



Upravljanje nesukladnostima

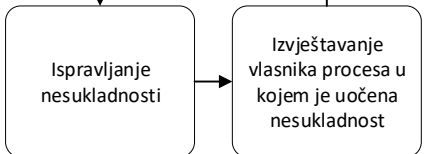
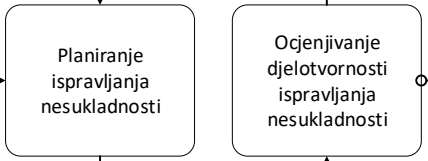
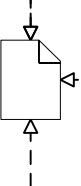
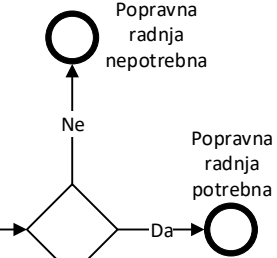
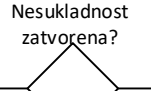
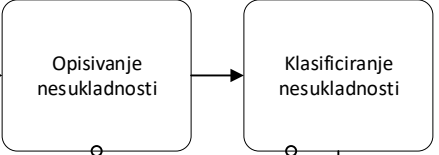
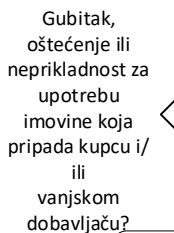
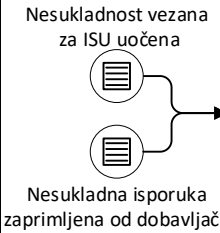
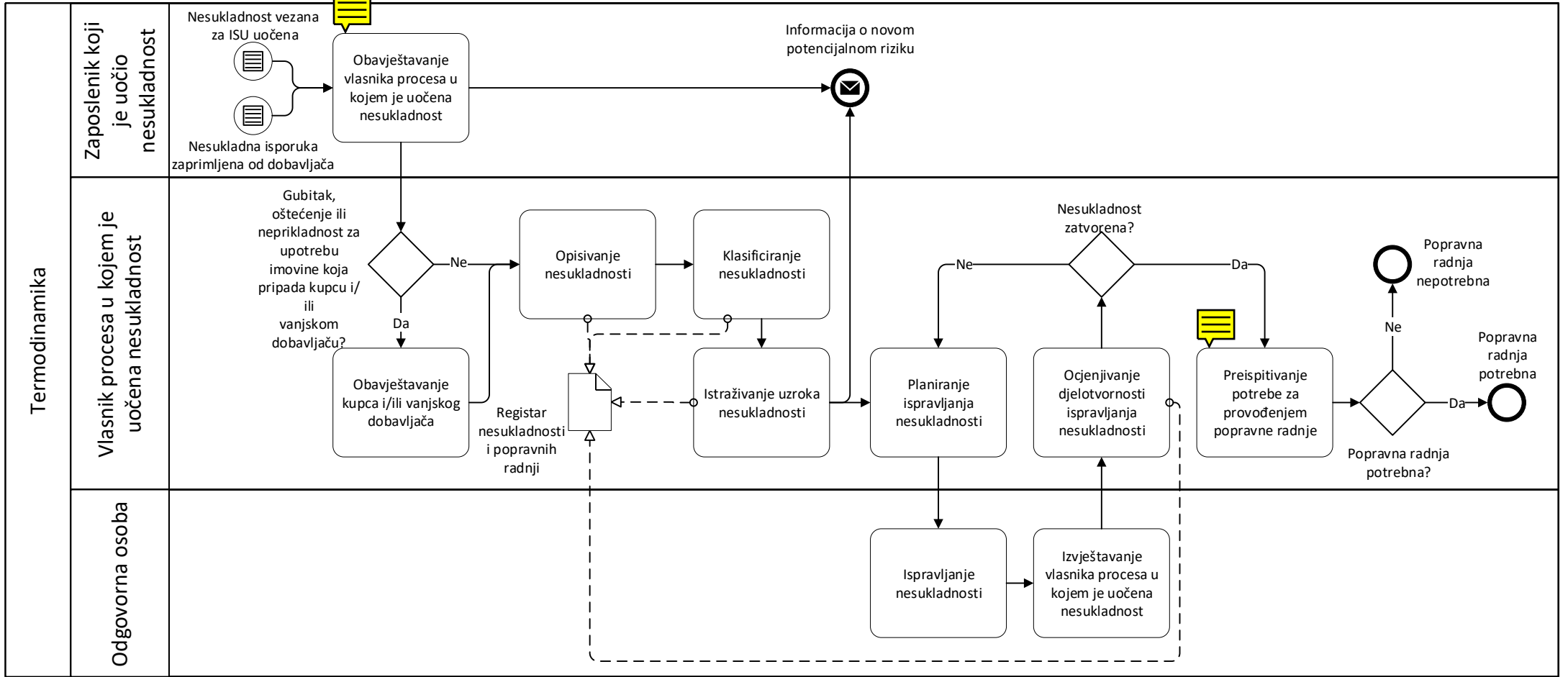



Upravljanje popravnim radnjama

